

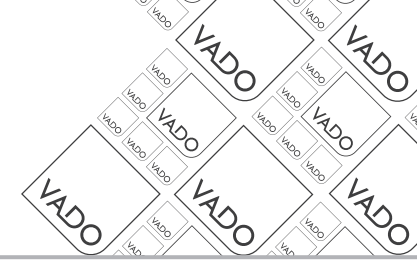

where inspiration flows

ZOO



Installation Guide 3 Hole Shower Mixer

This instruction booklet covers model:

ZOO-232NS-CP

ZOO-232NS-CP

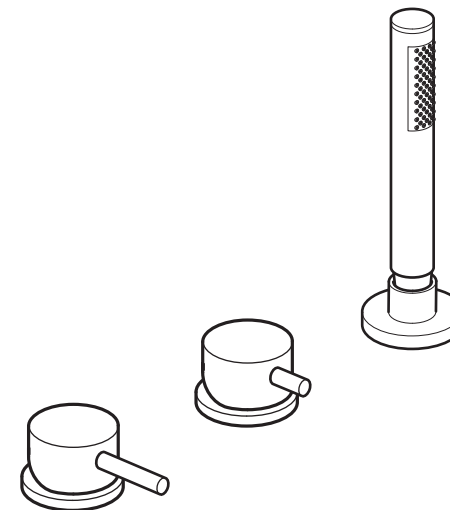

Vado
Wedmore Road, Cheddar, Somerset, England BS27 3EB
tel 01934 744466 fax 01934 744345
aftersales@vado.com
www.vado.com



Important - please read

Please read these instructions carefully before starting installation and keep for future reference.

Remove all packaging and check the product for missing parts or damage before starting installation.

Any alterations made to this product and fittings may infringe water regulations and will invalidate the guarantee.

The installation must comply with all Local/National Water Supply Authority Regulations/Byelaws and Building and Plumbing Regulations.

To be installed in accordance with BS EN806.

We strongly recommend that you use a qualified and registered plumber.

This product is not intended to protect against the ingress of water, please do not locate this under a direct flow of water.

If spray is likely to occur, water could backtrack under the bath/surface.

A capsule kit (NOT-CAPSULE-C/P, ZOO-CAPSULE-C/P) or appropriate tanking will help mitigate this.

General installation

This fitting is a mixing device and therefore water supplies should be reasonably balanced.

When installed, the fitting must comply with the requirements of the Water Supply (Water Fittings) Regulations 1999 and Scottish Byelaws 2004.

For further information, contact the Water Regulations department of your local water supplier (see the WRAS website www.wras.co.uk for details) or the Water Regulations Advisory Scheme by email (info@wras.co.uk) or telephone: 01495848454.

Before making any inlet pipe connections, all supply pipes MUST be thoroughly flushed to remove debris. Failure to do so could result in damage or low flow from the mixer unit.

The fitting of isolating valves to the inlet feeds is advised for ease of maintenance.

Please take great care when installing this mixer not to damage its surface.

Please note if installing in an enclosed environment, access should be left for servicing and maintenance. No costs relating to inadequate access can be accepted.

Operating Specifications

Operating Pressure

Minimum operating pressure - **3 bar**

Maximum operating pressure - **5 bar**

Notes:

Installation - shower

Position the connecting tube into the hole, from the underside slide on the rubber washer, metal washer and then the nut. Ensure the shroud is in the correct position/alignment.

Tighten the nut to clamp on the shroud.

CAUTION: Do not over tighten the nut.

Thread the small nut end of the shower hose down through the shroud and screw into the diverter valve.

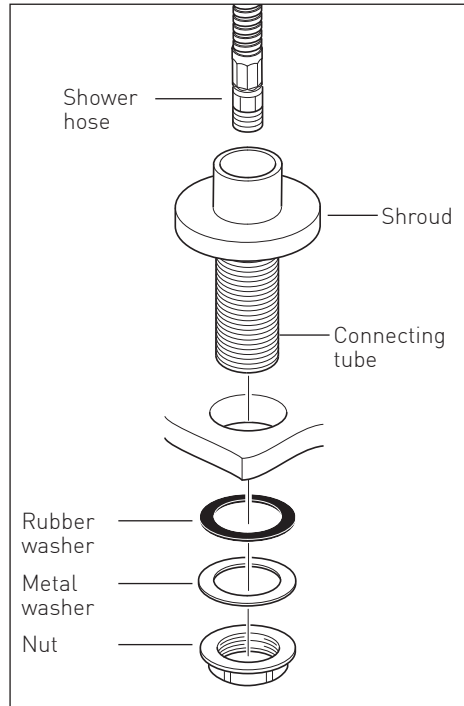

Handset

Place one of the rubber washer into the end of the hose and screw to the handset.

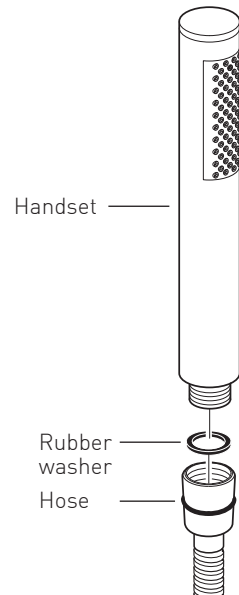

Contents of Packaging

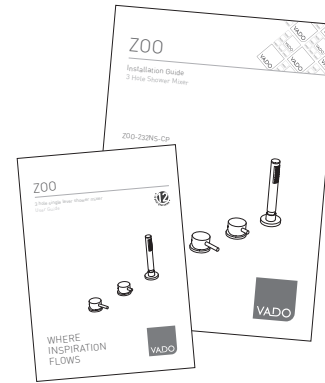

Installation guide & User manual

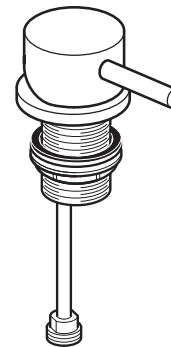
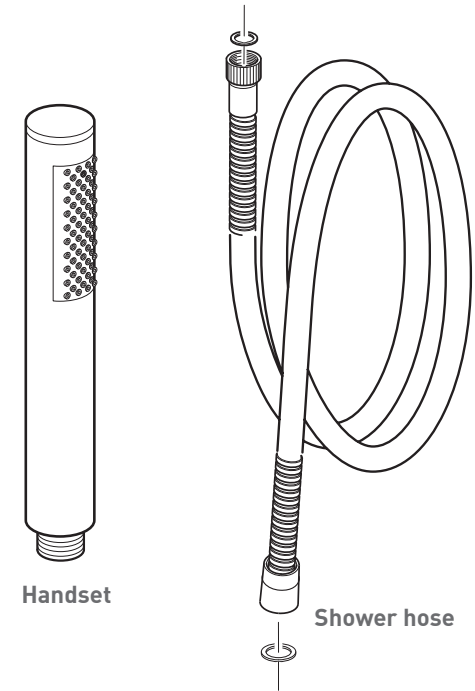

Mixer assembly



Diverter assembly

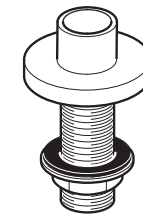

Handset Shroud

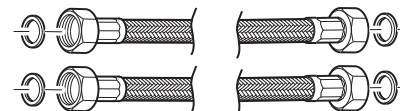

Flexible connecting pipe

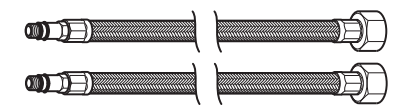

Flexible pipes - Hot and Cold inlets

Dimensions

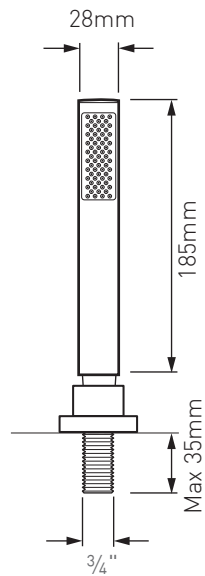
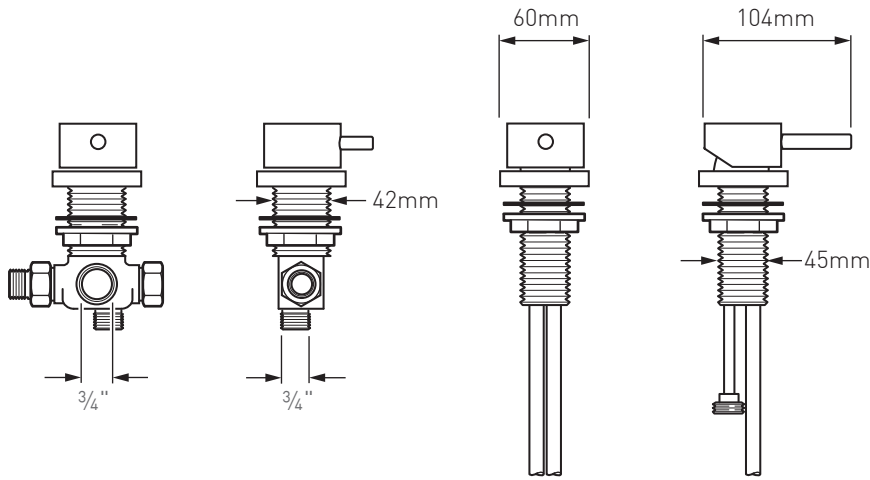

Installation - diverter

Drill a 44mm diameter hole in the required position.

Unscrew and remove the lip from valve.

Feed the diverter valve up through the deck hole, screw on the lip and tighten with a spanner.

Carefully push the control handle/shroud onto the splines within the valve and screw on the shroud, hand tighten only. Ensure the shroud is in the correct position/alignment.

From the underside tighten the nut to secure the valve in place.

CAUTION: Do not over tighten the nut as this might damage the unit.

Connect the flexible hose coming from the mixer to the bottom inlet ensure that the washer is fitted in the nut.

Connect the flexible hose to the threaded outlet ensure that the washer is fitted in the nut (this will be connected to your optional fitting).

The other outlet is fitted to the shower hose after the shower assembly has been fitted.

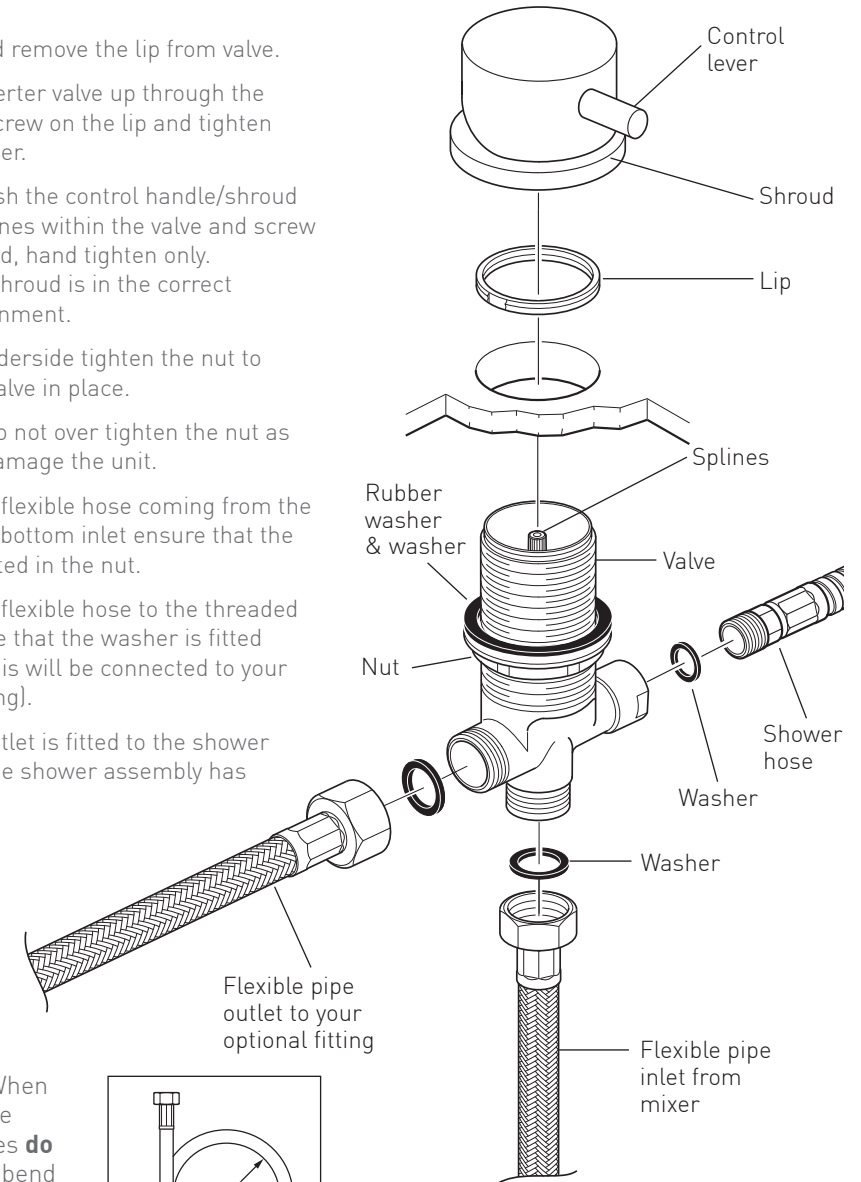

CAUTION: When installing the flexible hoses **do not** kink, or bend them more than the 60mm diameter as shown right.

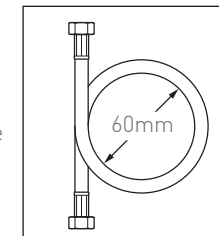

Installation - mixer

NOTE: Please refer to your relevant dimensions before starting the installation.

Before installing your new mixer, flush through the pipe work to ensure removal of debris, turn off the water supply.

Drill a 46mm diameter hole in the required position.

Remove the nut and washers and push the mixer down through the deck hole, slide the rubber washer and then the metal washer nut over the outlet pipe and screw onto the mixer. Ensure the shroud is in the correct position/alignment.

Tighten the nut to clamp the mixer to the unit.

CAUTION: Do not over tighten the nut as this may damage the unit.

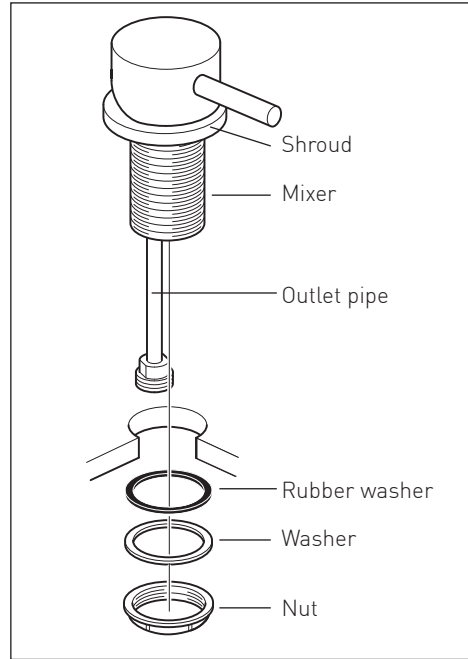

Screw the two flexible pipes to the hot and cold connections in the mixer body, the hot should be on the left and cold on the right, hand tighten only.

Connect the water supply to the inlet pipes. The hot water should be connected to the left hand pipe.

The back outlet pipe is connected to the diverter using the flexible pipe, ensure that the washer is fitted in the nut.

CAUTION: When installing the flexible hoses do not kink, or bend them more than 60mm in diameter.

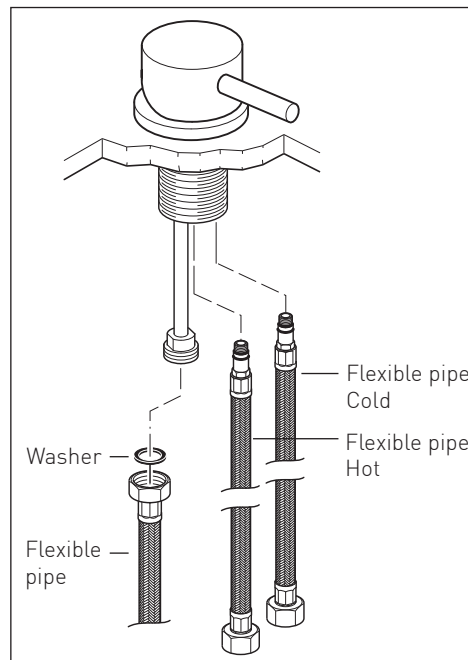

Installation - Quick guide

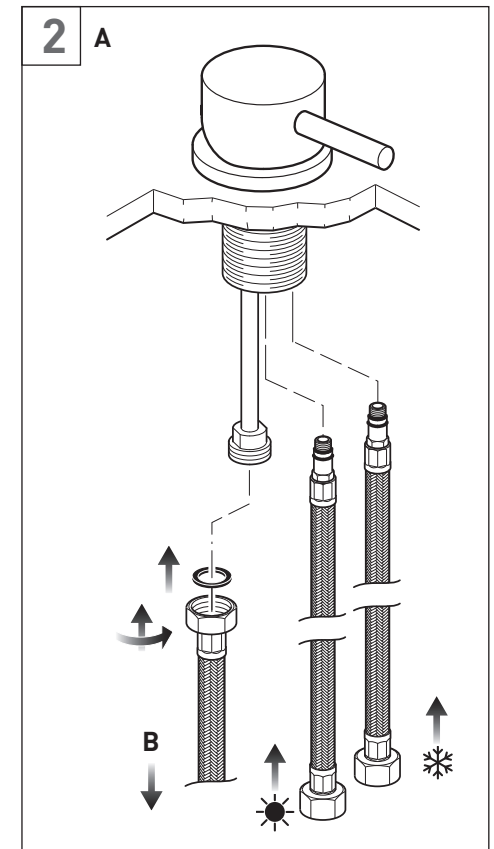
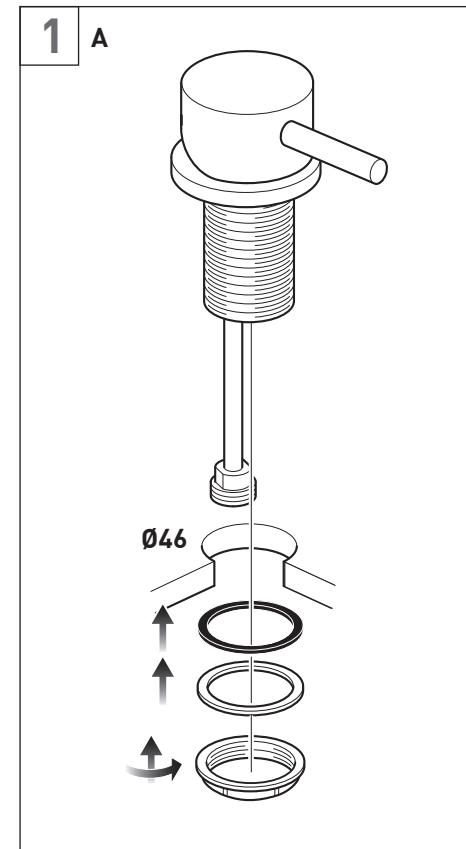
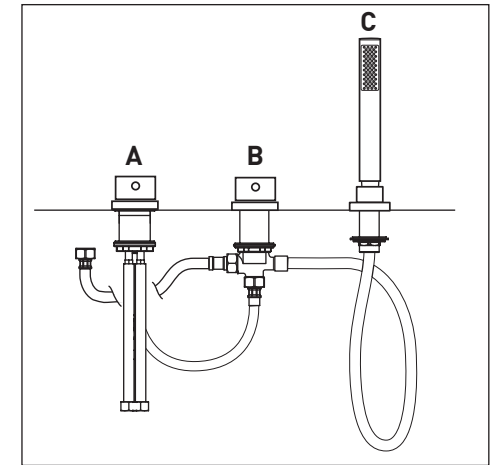

Installation - Quick guide

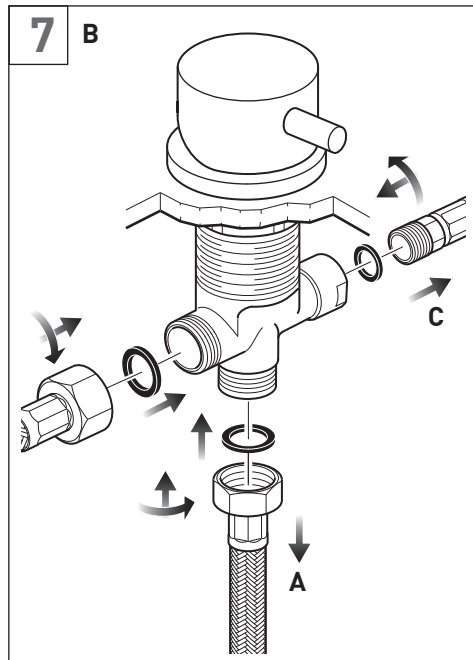
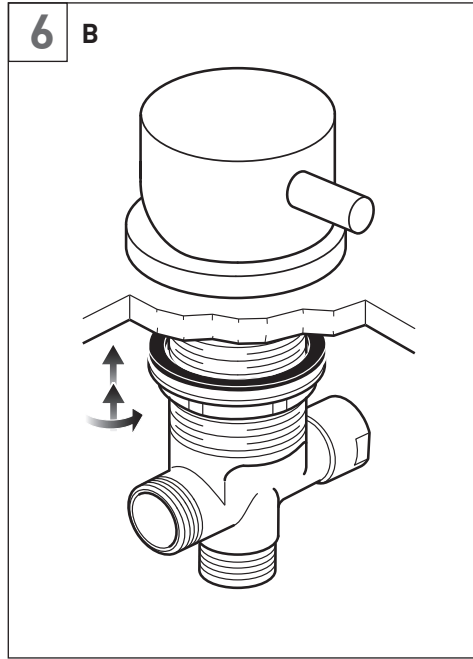
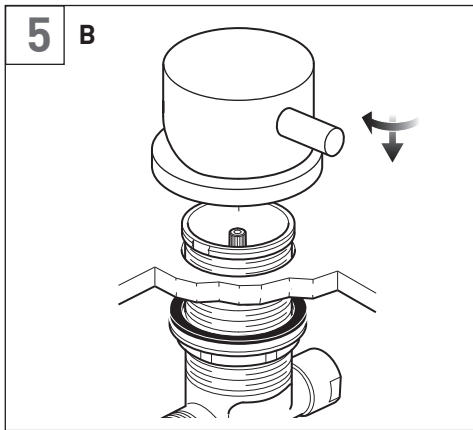
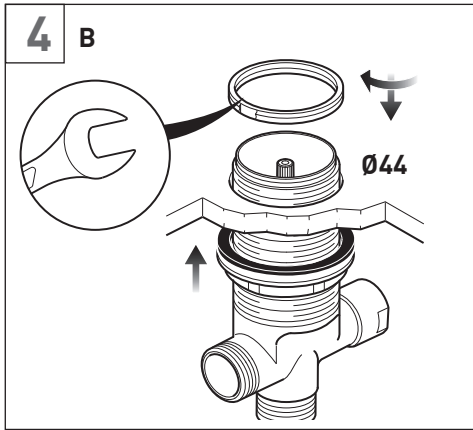
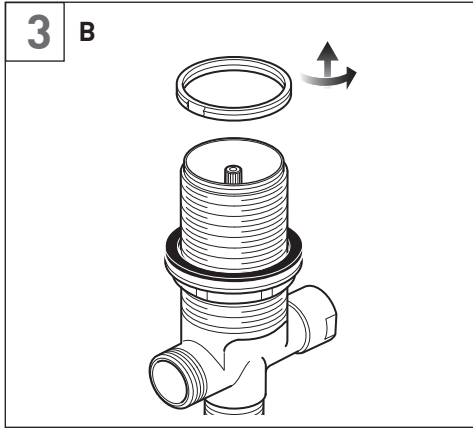

Installation - Quick guide

