

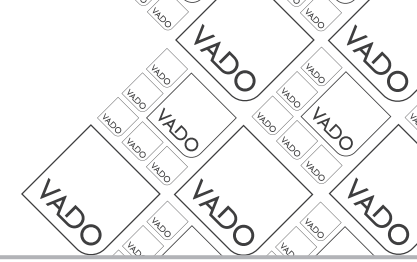

where inspiration flows



Installation Guide

This instruction booklet covers model:
CEL-148D/RO, CEL-148D/SQ, ELE-148D, LIF-148D, MIX-148D,
NOT-148D, ORI-148D, PHA-148D, PHO-148D.

CON-BV048D-BR

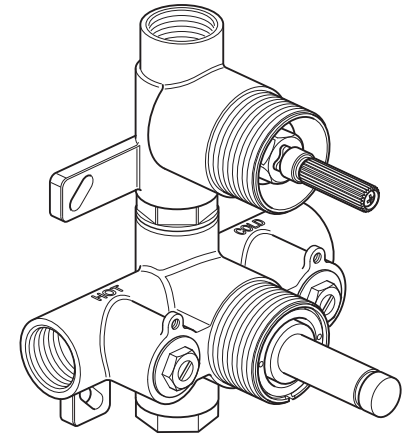

Vado
Wedmore Road, Cheddar, Somerset, England BS27 3EB
tel 01934 744466. fax 01934 744345
aftersales@vado.com
www.vado.com



Important - please read

Please read these instructions carefully before starting installation and keep for future reference.

Remove all packaging and check the product for missing parts or damage before starting installation.

Any alterations made to this product and fittings may infringe water regulations and will invalidate the guarantee.

The installation must comply with all Local/National Water Supply Authority Regulations/Byelaws and Building and Plumbing Regulations.

To be installed in accordance with BS EN806.

We strongly recommend that you use a qualified and registered plumber.

General installation

This fitting is a mixing device and therefore operating pressures (hot and cold supply) should be kept as balanced as possible in order to assure optimum efficiency.

When installed, the fitting must comply with the requirements of the Water Supply (Water Fittings) Regulations 1999 and Scottish Byelaws 2004.

For further information, contact the Water Regulations department of your local water supplier (see the WRAS website www.wras.co.uk for details) or the Water Regulations Advisory Scheme by email (info@wras.co.uk) or telephone: 01495848454.

Before making any inlet pipe connections, all supply pipes MUST be thoroughly flushed to remove debris. Failure to do so could result in damage or low flow from the mixer unit.

The fitting of strainers is recommended as close as practicable to the water supply inlets of the thermostatic mixing valve.

The fitting of isolation valves is required as close as is practicable to the water supply inlets of the thermostatic mixing valve.

If the concealed valve is connected to pipework that is fixed by soldering, it is essential the concealed valve is protected to prevent the check valves, thermostatic cartridge and headworks being exposed to elevated temperatures which can cause internal damage.

Please note: if installing in an enclosed environment, access should be left for servicing and maintenance. No costs relating to inadequate access can be accepted.

Operating Specifications

Operating Pressure

Minimum operating pressure for shower **0.2 bar**

Minimum operating pressure for bath **1 bar**

Maximum operating pressure **5 bar**

Operating specifications

Conditions of use for Type 2 valves

	High Pressure
Maximum Static Pressure (Bar)	10
Flow Pressure, Hot & Cold (Bar)	0.5 to 5
Hot Supply Temperature (°C)	55 to 65
Cold Supply Temperature (°C)	Equal to or Less than 25

Note: Valves operating outside these conditions cannot be guaranteed by the Scheme to operate as Type 2 valves.

Valve designation: HP-S-T.

If a water supply is fed by gravity then the supply pressure should be verified to ensure the conditions of use are appropriate for the valve.

Recommended outlet temperatures

The industry recommends the following mixed water outlet temperature for use in all premises:

44° C for bath fill but see notes below;

41° C for showers;

The mixed water temperatures must never exceed 46° C.

The maximum mixed water temperature can be 2° C above the recommended maximum set outlet temperatures.

Note:

46° C is the maximum mixed water temperature from the bath tap. The maximum temperature takes account of the allowable temperature tolerances inherent in thermostatic mixing valves and temperature losses in metal baths.

It is not a safe bathing temperature for adults or children.

The British Burns Association recommends 37° to 37.5° C as a comfortable bathing temperature for children. In premises covered by the Care Standards ACT 2000, The maximum mixed water outlet temperature is 43° C.

The thermostatic mixing valve will be installed in such a position that maintenance of the TMV and its valves and the commissioning and testing of the TMV can be undertaken.

Operating Specifications

In-service testing:

It is recommended that all TYPE 2 approved valves are tested and evaluated against the commissioning setting results once a year. Whilst this is a recommendation in user / owner domestic dwellings, a duty of care obligation should be considered in commercial bathroom or subletting situations. When in-service testing is undertaken the following performance checks shall be carried out.

1. The supply conditions (temperatures & pressures) are broadly the same as they were at the time of installation.
2. Measure the mixed water temperature at the outlet(s).
3. Carry out the cold-water isolation test.

If there is no significant change to the set outlet temperature ($\pm 2^{\circ}\text{C}$ or less change from the original settings) and the cold-water isolation test criteria is achieved, then the valve is working correctly, and no further service work is required. If the performance falls outside of that acceptance criteria, then service or adjust the valve in line with the manufacturer's instructions.

Notes

If there is a residual flow during the commissioning or the annual verification (cold water supply isolation test), then this is acceptable providing the temperature of the water seeping from the valve is no more than 2°C above the designated maximum mixed water outlet temperature setting of the valve.

Temperature readings should be taken at the normal flow rate after allowing for the system to stabilise.

The sensing part of the thermometer probe must be fully submerged in the water that is to be tested.

Any TMV that has been adjusted or serviced must be re-commissioned and re-tested in accordance with the manufacturers' instructions.

Contents of Packaging

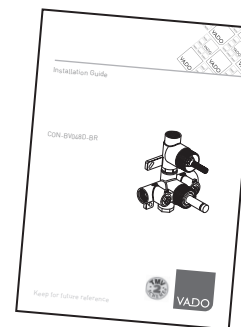

Installation guide

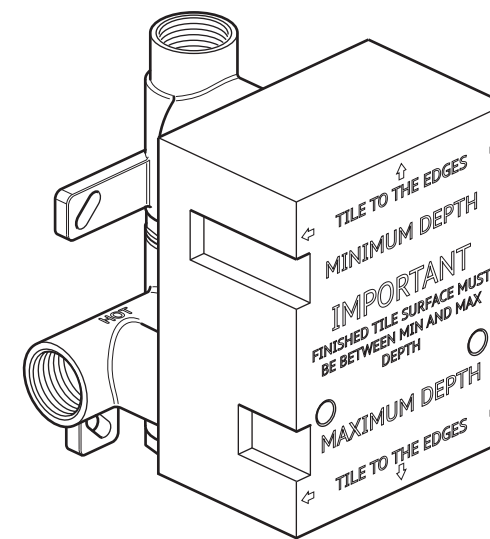

Valve body
(with mortar guard)

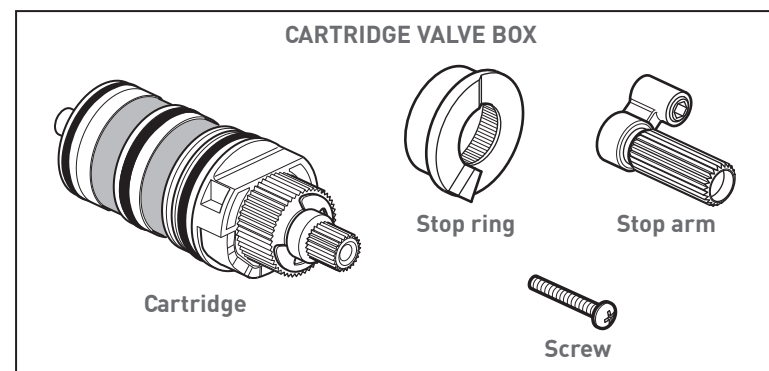

Valve dimensions

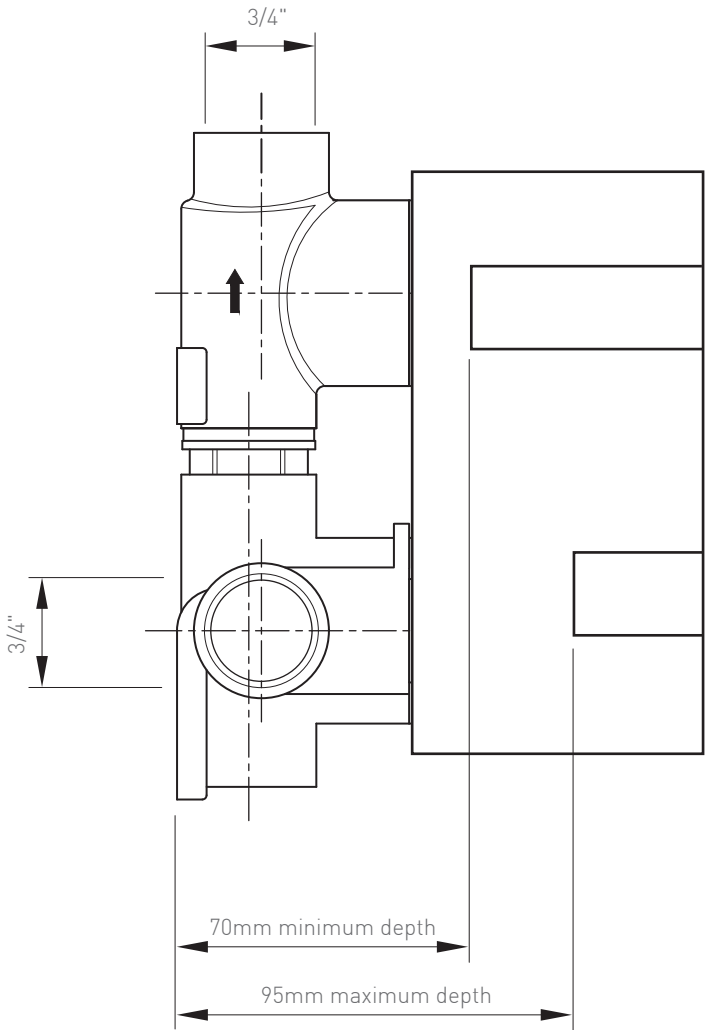

Installation - Quick guide

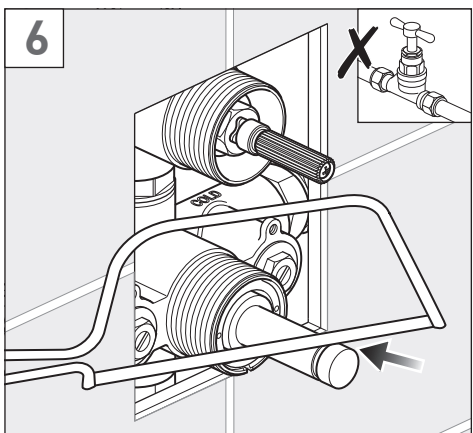
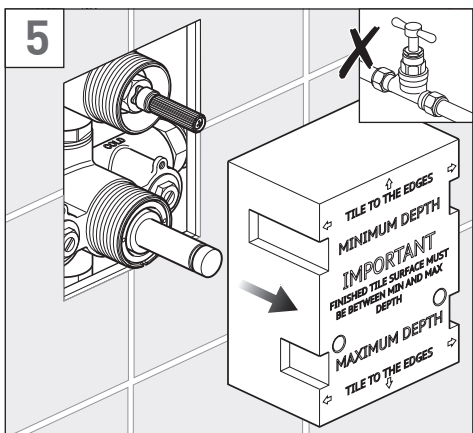
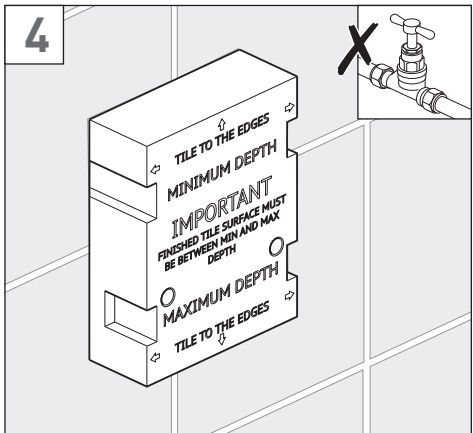
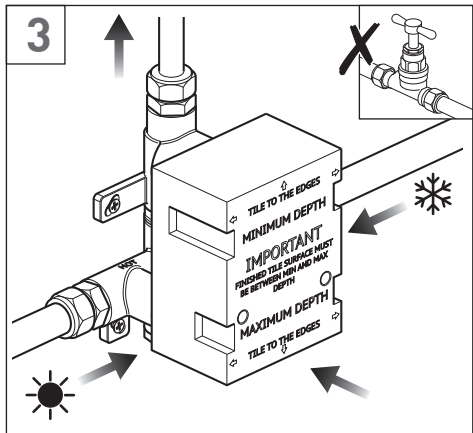
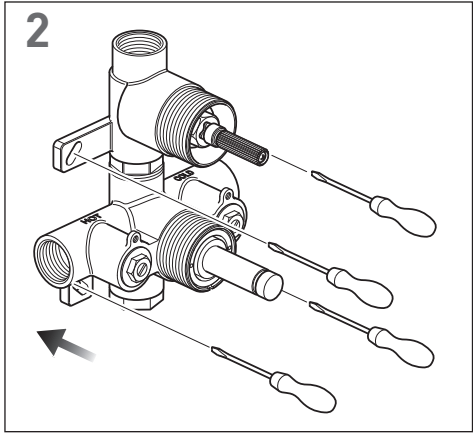
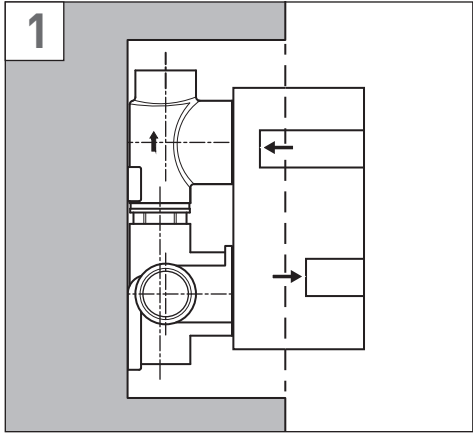

Installation - Quick guide

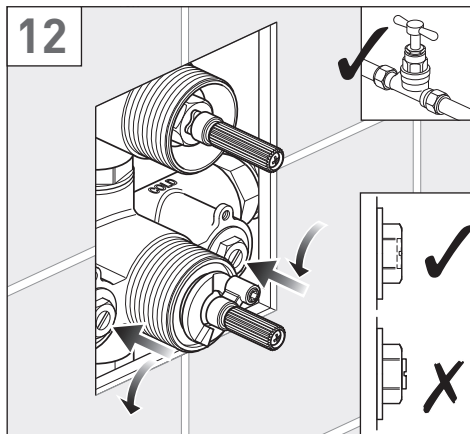
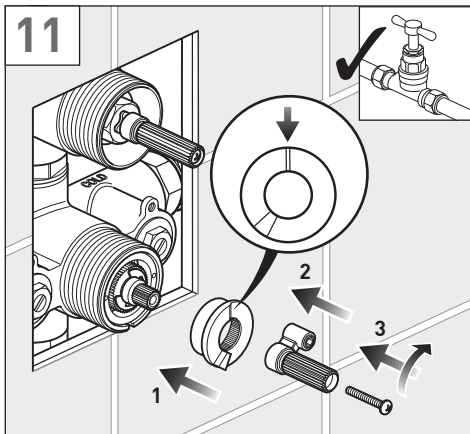
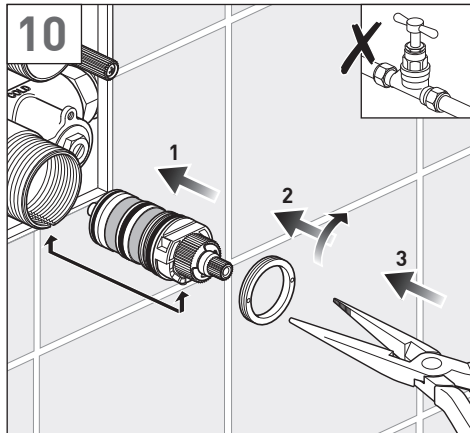
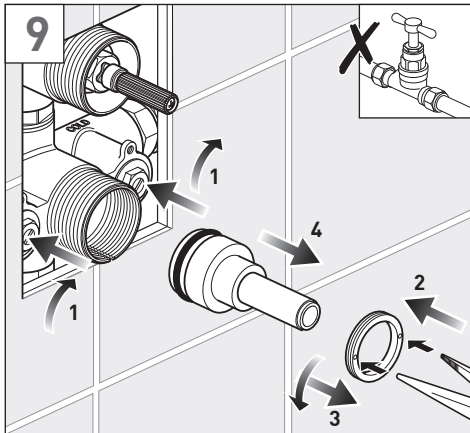
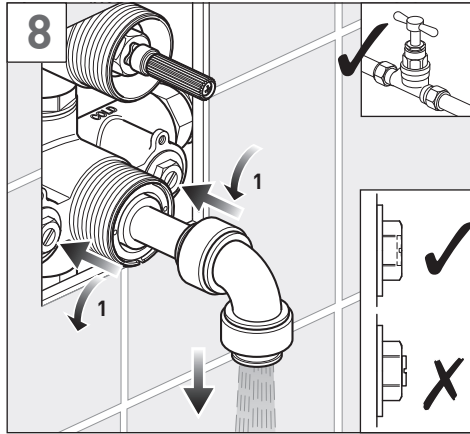
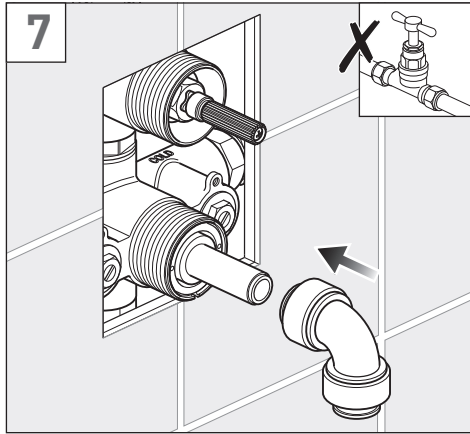

Installation

Mortar guard

During and after installation protect the outer parts by leaving the mortar guard on the valve to avoid damage to plated surfaces.

Remove the mortar guard by releasing the two screws and pulling off.

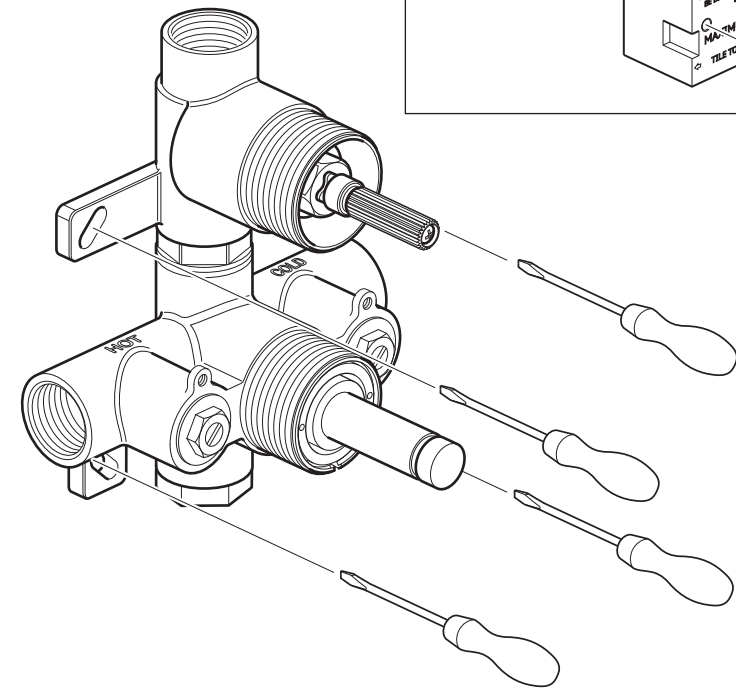
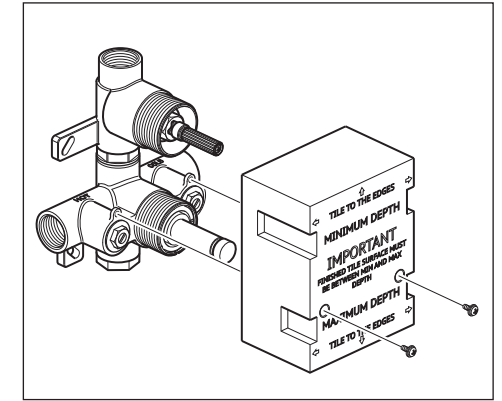

Warning! Please check for any hidden cables and pipes before drilling holes in the wall.

The back of the valve must be set into the wall between (70mm minimum - 95mm maximum) from the face of the finished wall.

Select the position for the shower valve and offer the shower valve to the wall, make sure the valve is vertical with a level and fixed to a flat surface, mark the 4 fixing points with a suitable pencil.

Secure using suitable fixings.

Replace the mortar guard and secure in position with the two screws.

Installation

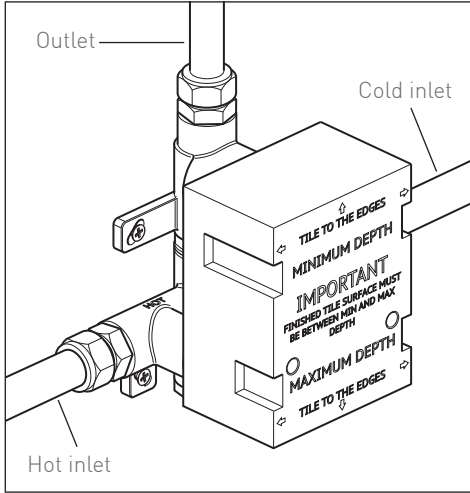

Connect hot supply to the lower left inlet of the valve and cold supply to the lower right inlet. Connect the top outlet to the desired channel.

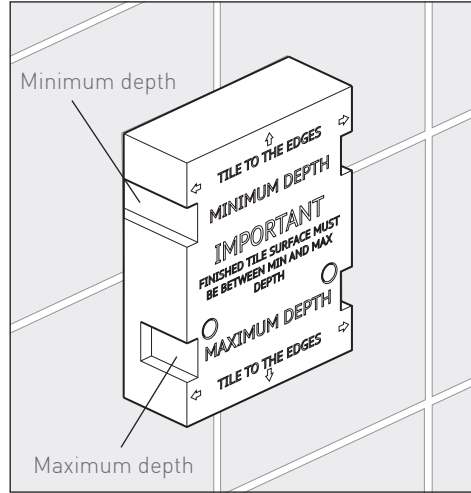

Finish the wall by tiling up to the mortar guard, keep the final finished wall surface between the min and max marks. Unscrew the 2 mortar guard screws and remove from the wall.

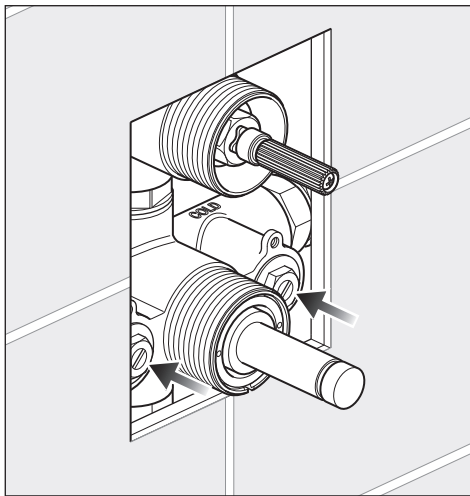

Turn off both non return valves by turning clockwise, do not overtighten.

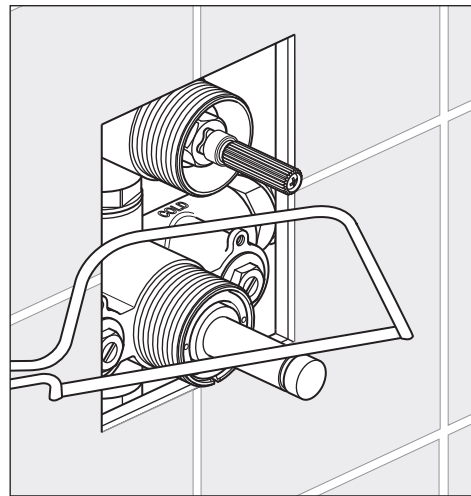

Important: ensure the hot and cold water supplies have been isolated. Using a suitable tool, cut the end off the drain through the easy cut section.

Installation

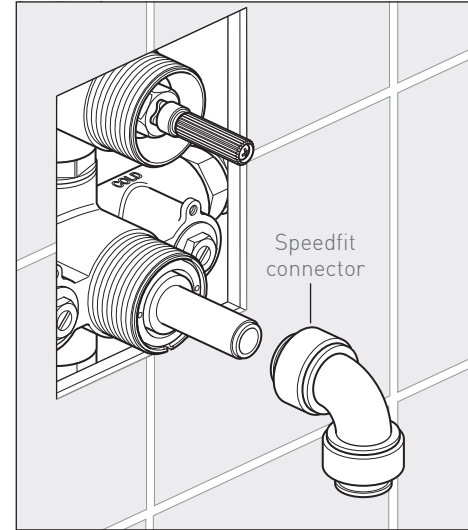

We recommend to push a speedfit connector (not supplied) over the drain, and place a bucket underneath. If a speedfit connector is not being used, carefully hold a bucket underneath the drain valve.

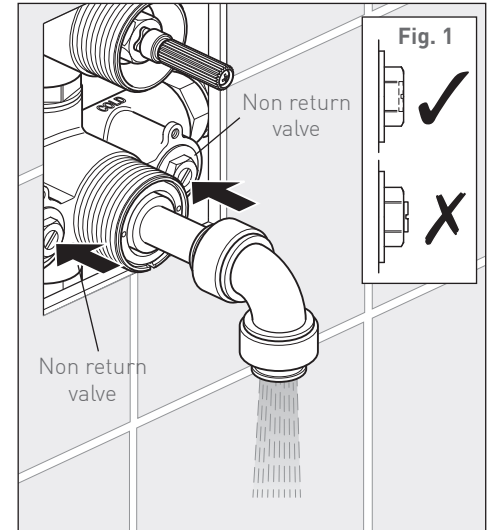

Turn on at the mains, open both non return valves and allow the debris and water to drain. When loosening the non return valve do not unscrew further than the face of the nut (see Fig. 1). After approximately two minutes of flushing the pipe work and product close both non return valves. Do not overtighten.

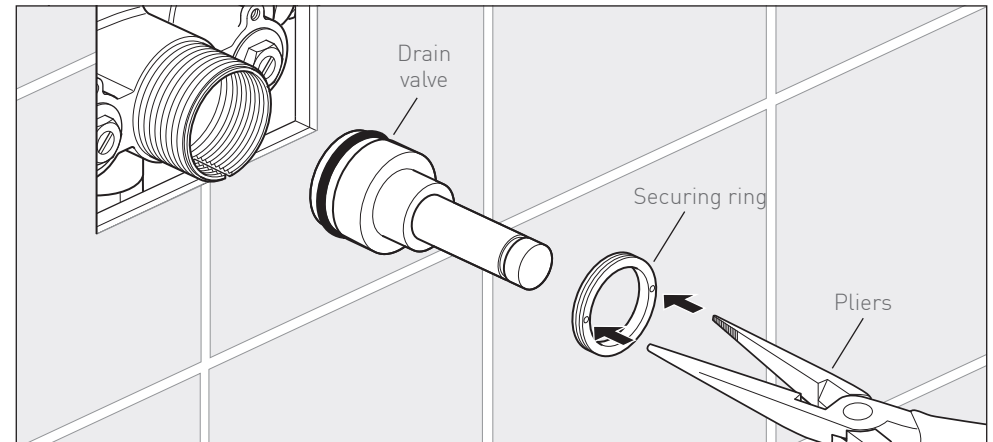

Remove the speedfit connector. Using a pair of long-nosed pliers unscrew the securing ring and remove. Pull the drain valve out from the body

Installation

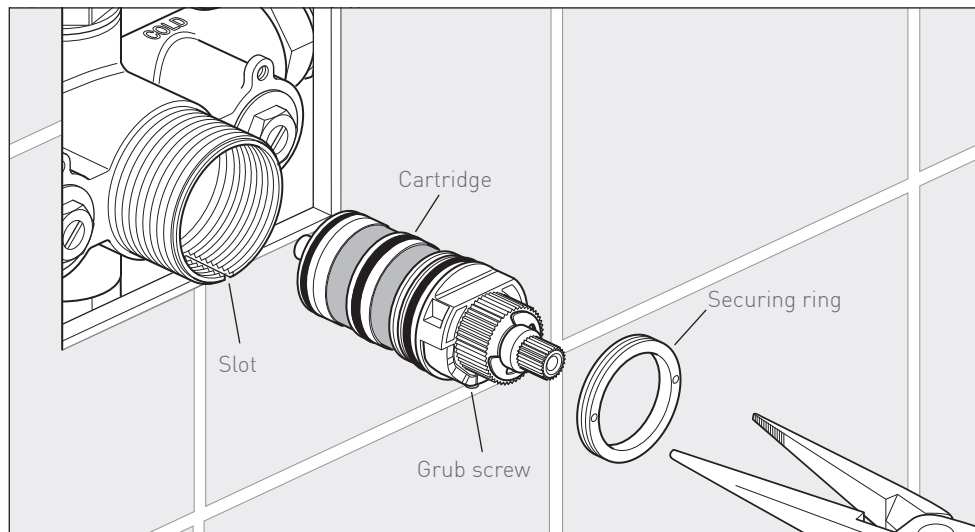

Push the cartridge into the body, align the grub screw with the slot and continue to push the cartridge all the way in.

Fit the securing ring and tighten using a pair of long-nosed pliers

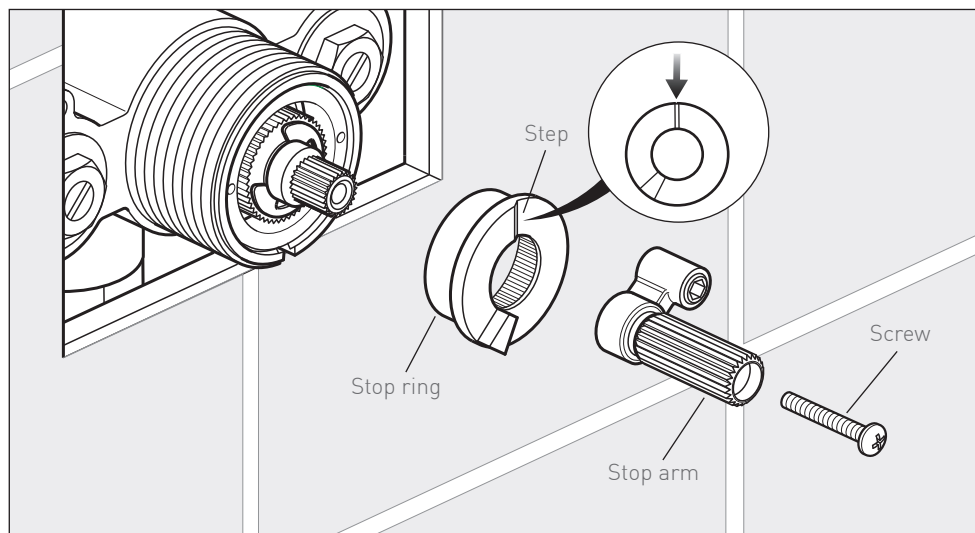

Push the stop ring onto the splines of the cartridge, making sure that the step on the stop ring is at 12 o'clock.

Slide the stop arm on and secure in position with the screw.

Notes

Notes

Notes