

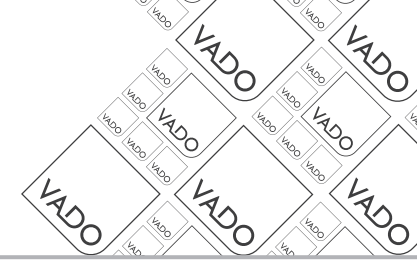

it's a personal experience

# OMIKA



Installation Guide  
Wall Mounted Basin Mixer

This instruction booklet covers this model:  
OMI-109.

109

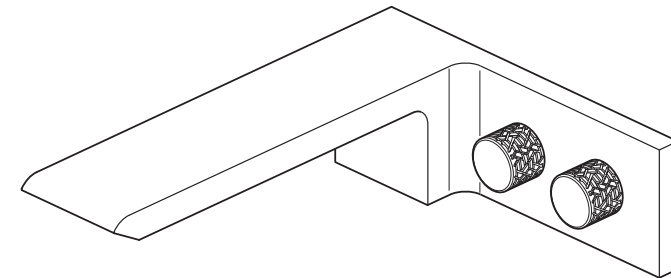

Vado  
Wedmore Road, Cheddar, Somerset, England BS27 3EB  
tel 01934 744466. fax 01934 744345  
aftersales@vado.com  
www.vado.com



## Contents

Important information.....	3
General information.....	3
Operating Specifications.....	3
Contents of packaging.....	4
Dimensions.....	5
Installation - Quick guide.....	6
Installation.....	8

## Notes

## Installation

Carefully slide the spout over the splines on the valve and then the pins on the bracket. Keep sliding on until the back of the spout assembly touches the wall.

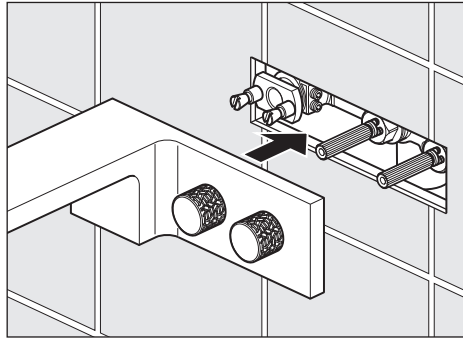

Remove the two grub screw covers on the underside of the spout and using the supplied hexagonal key tighten the two grub screws, replace the covers.

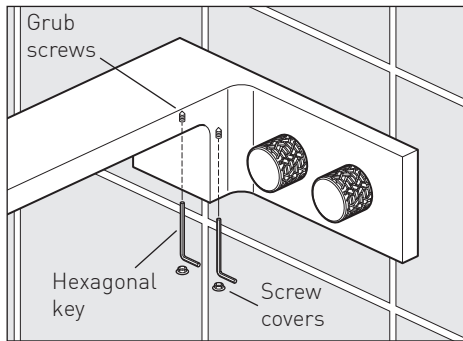

## Important - please read

Please read these instructions carefully before starting installation and keep for future reference.

Remove all packaging and check the product for missing parts or damage before starting installation.

Any alterations made to this product and fittings may infringe water regulations and will invalidate the guarantee.

The installation must comply with all Local/National Water Supply Authority Regulations/Byelaws and Building and Plumbing Regulations.

To be installed in accordance with BS EN806.

We strongly recommend that you use a qualified and registered plumber.

## General installation

This fitting is a mixing device and therefore water supplies should be reasonably balanced.

When installed, the fitting must comply with the requirements of the Water Supply (Water Fittings) Regulations 1999 and Scottish Byelaws 2004. Please check with your local water undertaker if there is any uncertainty.

Before making any inlet pipe connections, all supply pipes MUST be thoroughly flushed to remove debris. Failure to do so could result in damage or low flow from the mixer unit. Water Supply (Water Fittings) Regulations 1999 Schedule 2 Section 13.

The fitting of isolating valves to the inlet feeds is advised for ease of maintenance.

Please take great care when installing this mixer not to damage its surface.

Please note if installing in an enclosed environment, access should be left for servicing and maintenance. No costs relating to inadequate access can be accepted.

## Operating Specifications

### Operating Pressure

**Minimum operating pressure** - 1 bar

**Maximum operating pressure** 5 bar

# Contents of Packaging



**Installation guide & User manual**

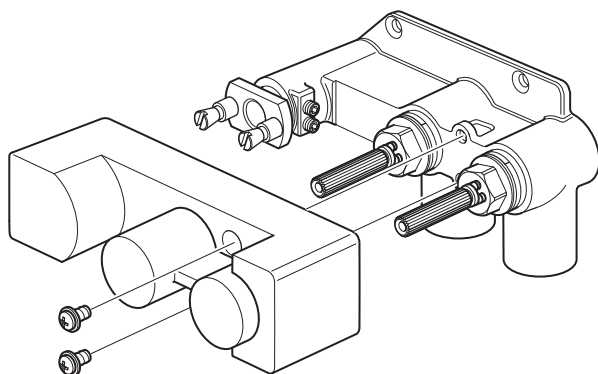

**Valve body**  
(Mortar guard with 2 x fixing screws)

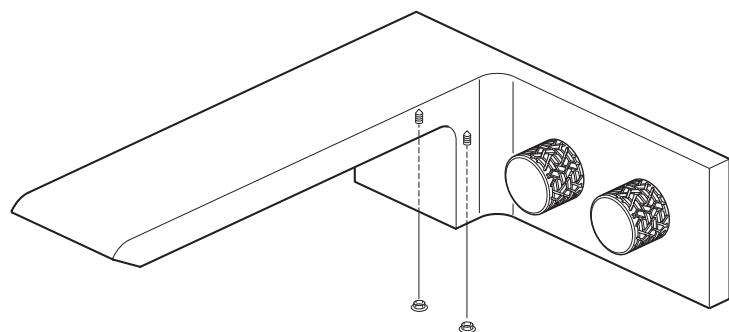

**Spout**  
(2 x grub screws with covers)

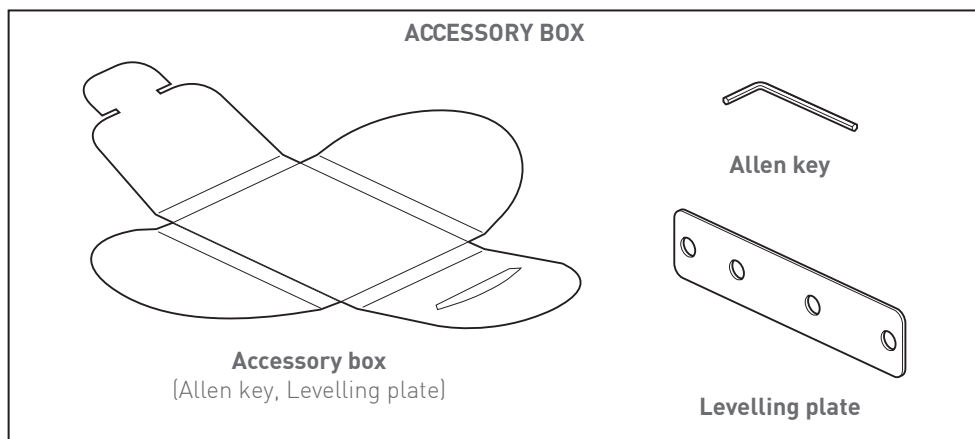

**ACCESSORY BOX**

**Accessory box**  
(Allen key, Levelling plate)

**Allen key**

**Levelling plate**

# Installation

Finish the wall by tiling up to the mortar guard, keep the final finished wall surface between the **MIN** and **MAX** marks. Shown at the **MIN** position see right. Unscrew the 2 mortar guard screws and remove from the wall.

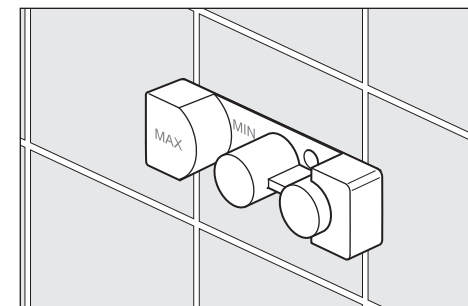

Using the supplied hexagonal key, release the 2 grub screws on the side of the valve. Adjust the spout bracket by sliding it in or out until the spout bracket is level with the face of the finished wall, see detail.

**Do not tighten the grub screws.**

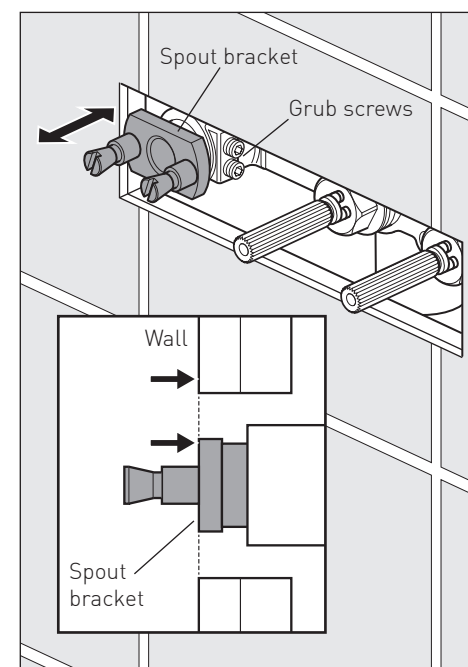

Carefully slide the levelling plate over the splines of the handles. Without moving the spout bracket in or out slide the levelling plate over the pins on the spout bracket, you may need to rotate the bracket slightly, this will level up bracket ready for the spout.

Check the position and tighten the two grub screws to lock the spout bracket in position.

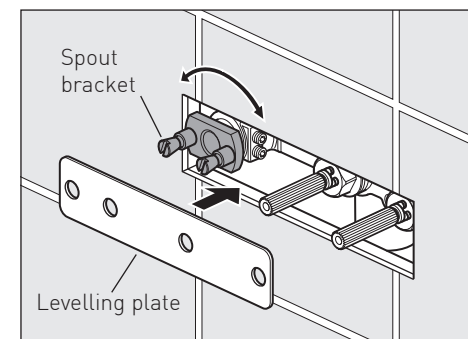

## Installation

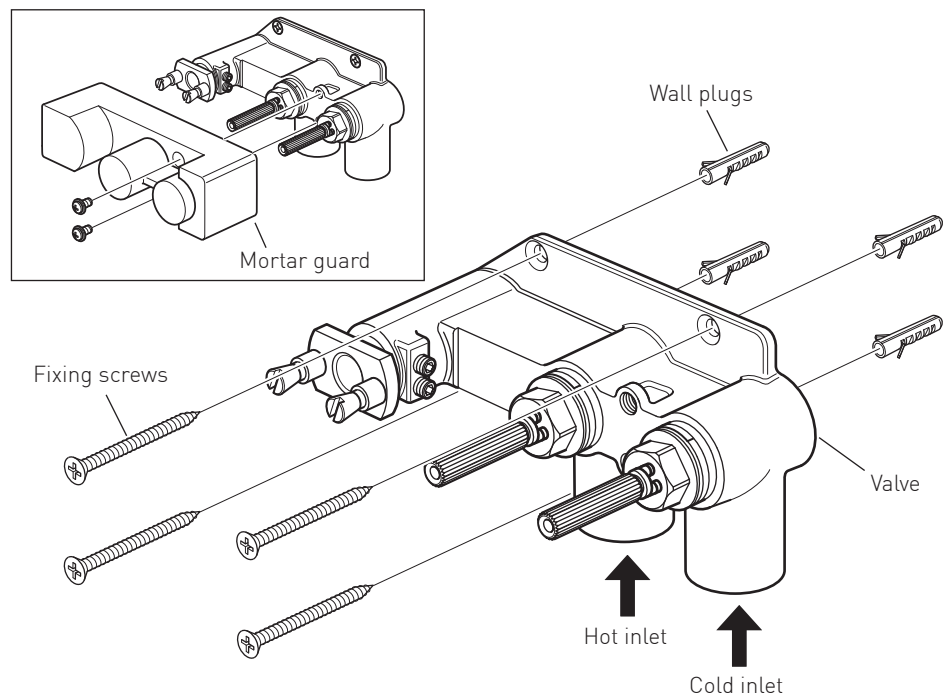

### Please note:

Before installing your new mixer, flush through the pipe work to ensure removal of debris, turn off the water supply.

### ⚠ Warning!

Please check for any hidden cables and pipes before drilling holes in the wall.

### Mortar guard

During installation protect the outer parts by leaving the guard on to avoid any damage to the valve.

### The valve must be set into the wall by 59.5 - 81.5mm (see dimension page).

Position the valve level in the correct position, mark the four fixing points of the valve. Using suitable fixings secure in position.

Make all connections to the valve. Connect hot supply to bottom left inlet of the valve and cold supply to the bottom right inlet.

## Valve dimensions

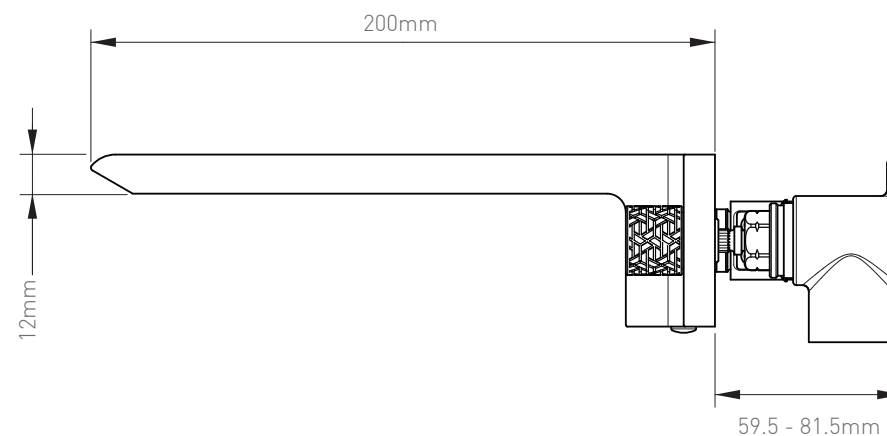
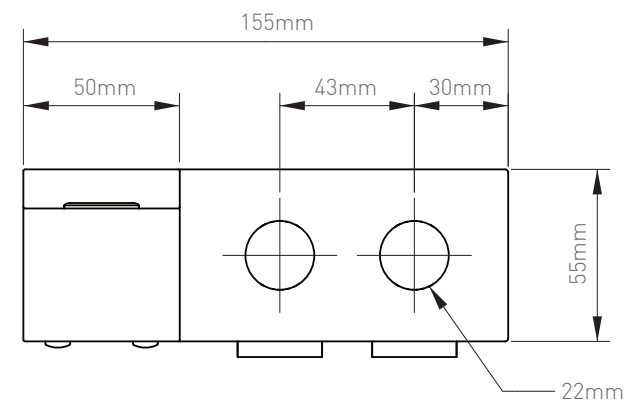

# Installation - Quick guide

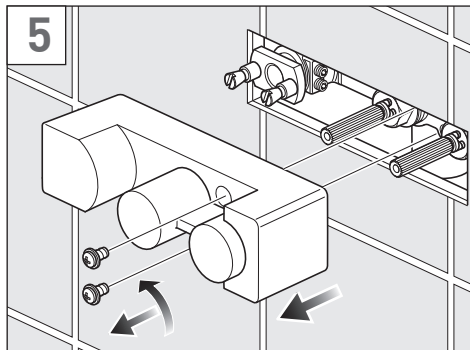
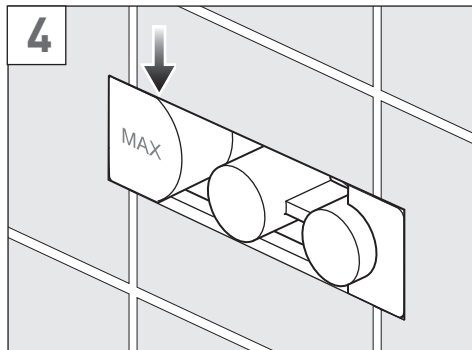
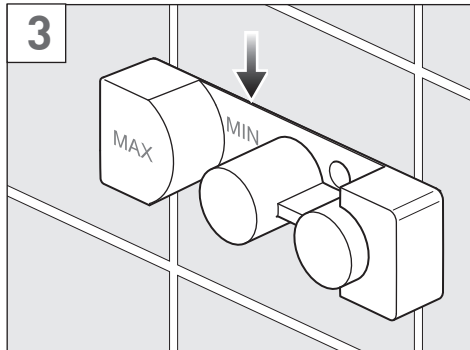
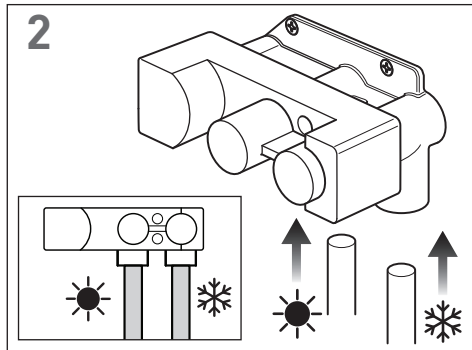
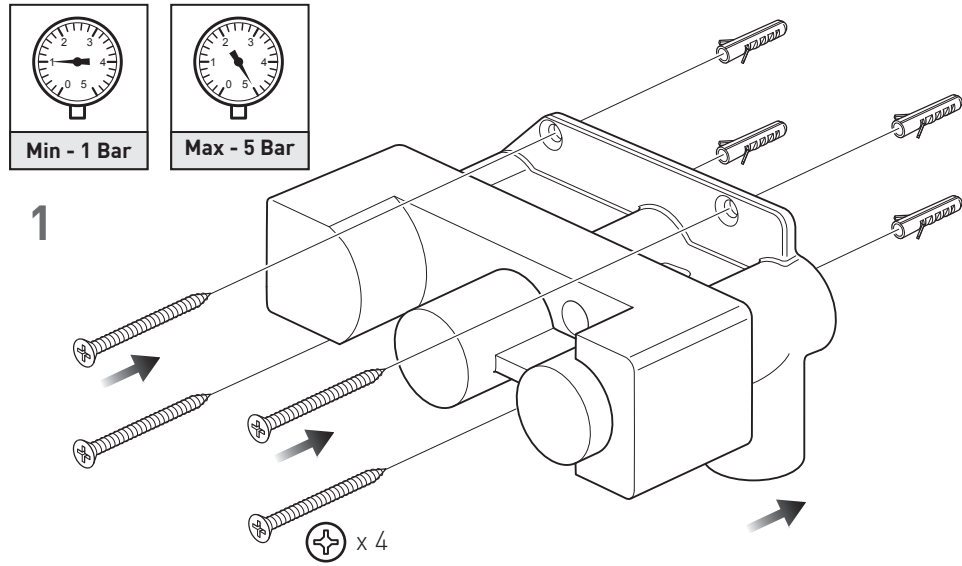

# Installation - Quick guide

