



where inspiration flows

EDIT

Installation Guide
Bath shower mixer with shower kit

This instruction booklet covers these models:
EDI-130+K-CP

EDI-130+K-CP

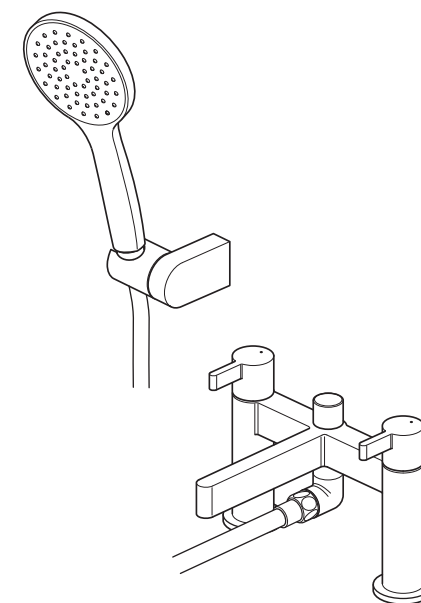

Vado
Wedmore Road, Cheddar, Somerset, England BS27 3EB
tel 01934 744466. fax 01934 744345
aftersales@vado.com
www.vado.com



Important - please read

Please read these instructions carefully before starting installation and keep for future reference.

Remove all packaging and check the product for missing parts or damage before starting installation.

Any alterations made to this product and fittings may infringe water regulations and will invalidate the guarantee.

The installation must comply with all Local/National Water Supply Authority Regulations/Byelaws and Building and Plumbing Regulations.
To be installed in accordance with BS EN806.

We strongly recommend that you use a qualified and registered plumber.

General installation

This fitting is a mixing device and therefore water supplies should be reasonably balanced.

When installed, the fitting must comply with the requirements of the Water Supply (Water Fittings) Regulations 1999 and Scottish Byelaws 2004.

For further information, contact the Water Regulations department of your local water supplier (see the WRAS website www.wras.co.uk for details) or the Water Regulations Advisory Scheme by email (info@wras.co.uk) or telephone: 01495848454.

Before making any inlet pipe connections, all supply pipes MUST be thoroughly flushed to remove debris. Failure to do so could result in damage or low flow from the mixer unit. Water Supply (Water Fittings) Regulations 1999 Schedule 2 Section 13.

The fitting of isolating valves to the inlet feeds is advised for ease of maintenance.

Please take great care when installing this mixer not to damage its surface.

Please note if installing in an enclosed environment, access should be left for servicing and maintenance. No costs relating to inadequate access can be accepted.

Operating Specifications

Operating Pressure

Minimum operating pressure **1 bar**

Maximum operating pressure **5 bar**

Contents of Packaging



Installation guide &
User manual

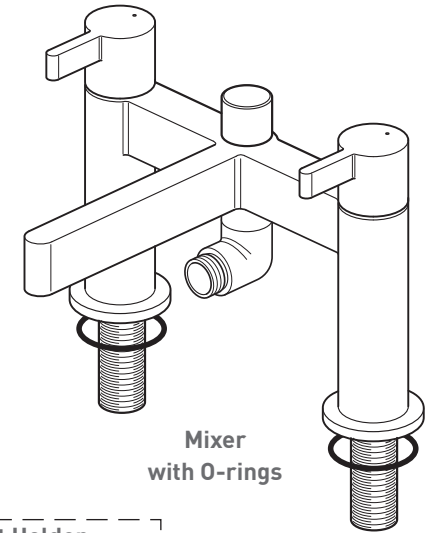

Mixer
with O-rings

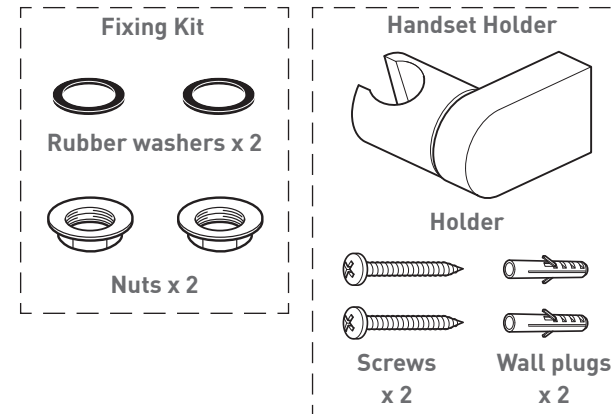

Fixing Kit
Rubber washers x 2
Nuts x 2

Handset Holder
Holder
Screws x 2
Wall plugs x 2

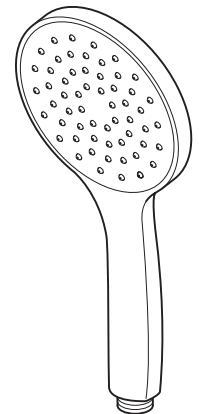

Handset

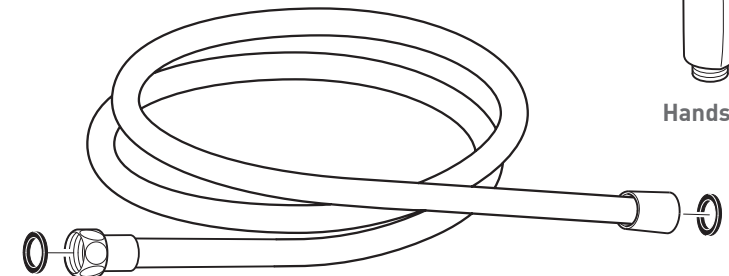

Shower hose with 2 washers

Dimensions

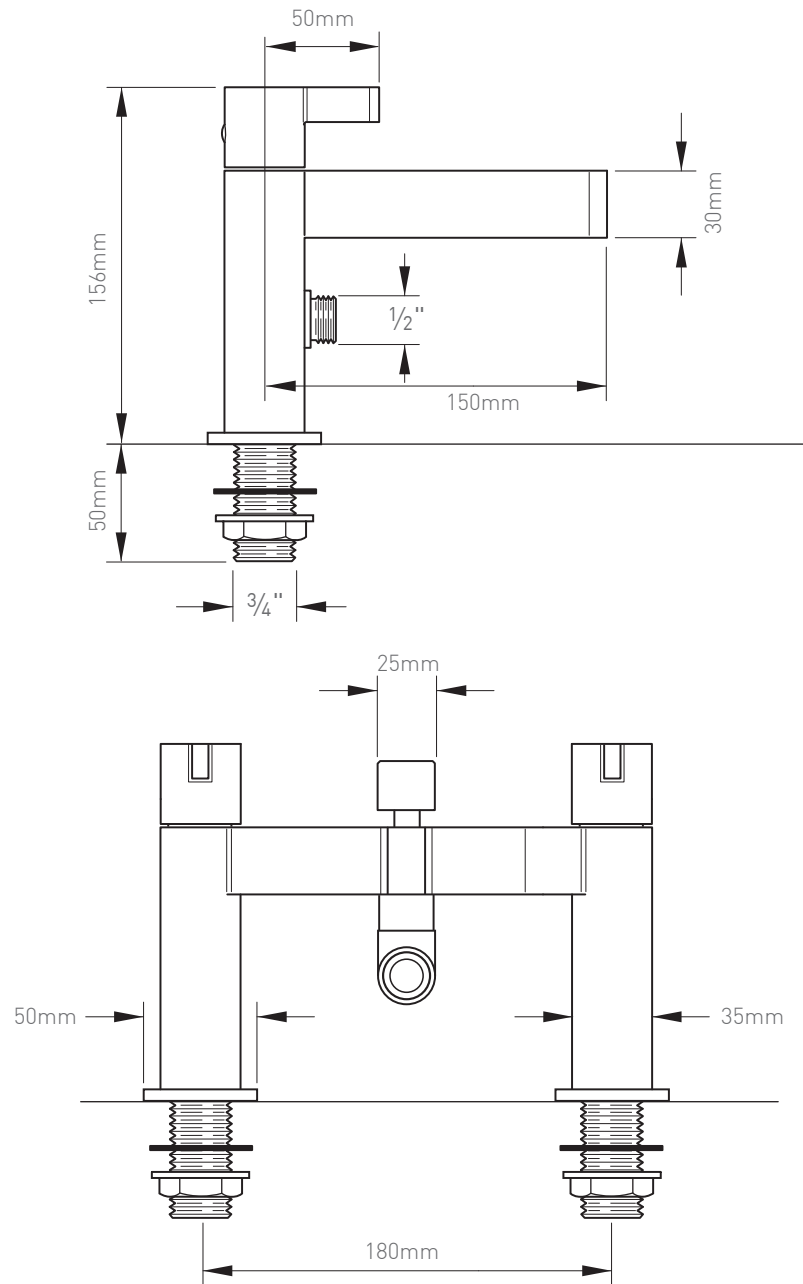

Installation - Quick guide

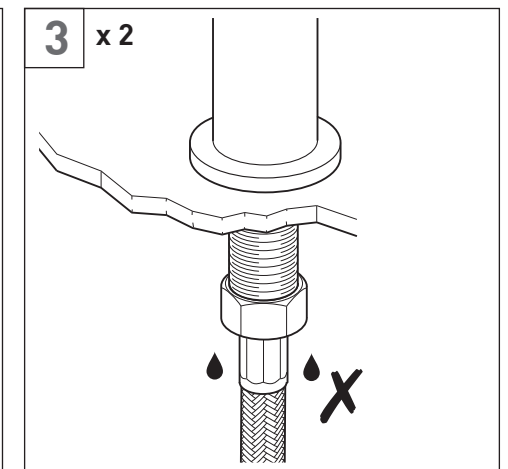
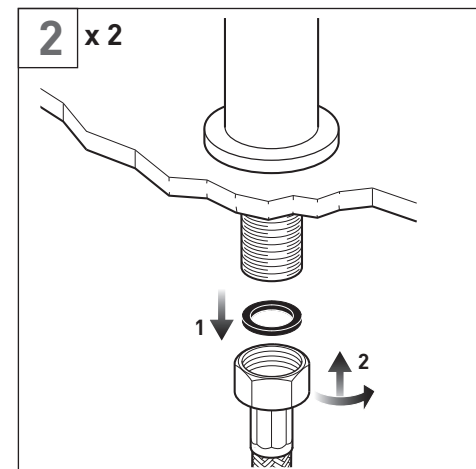
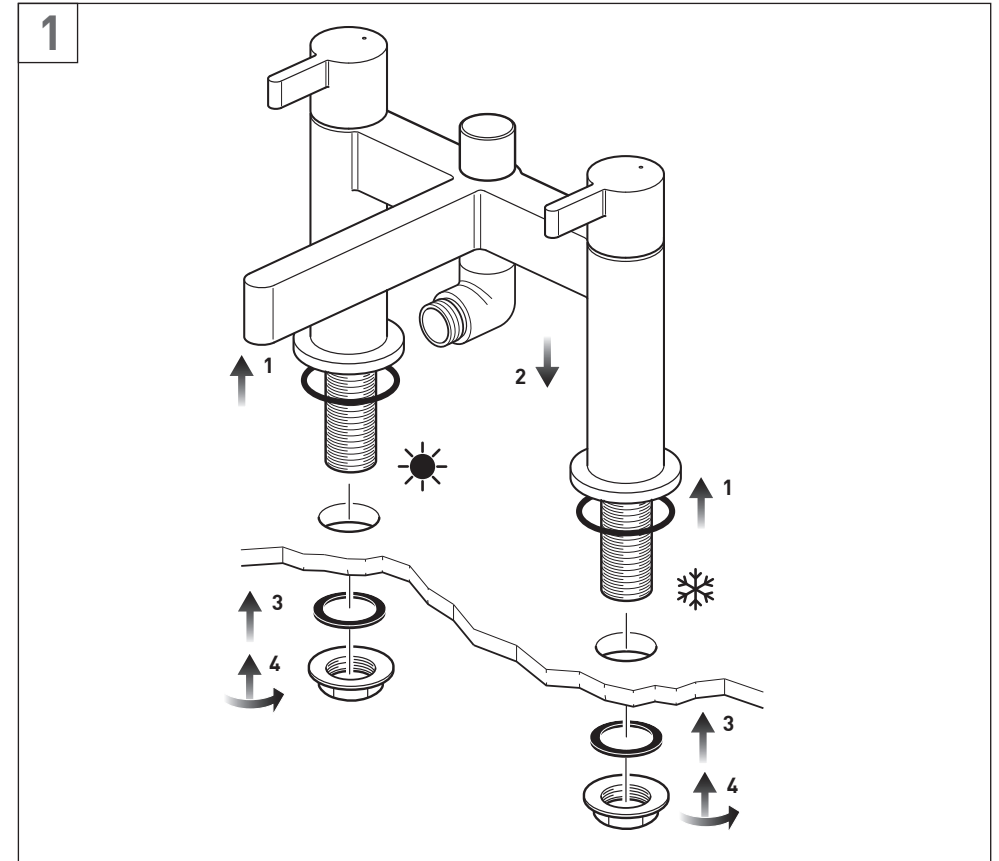

Installation - Quick guide

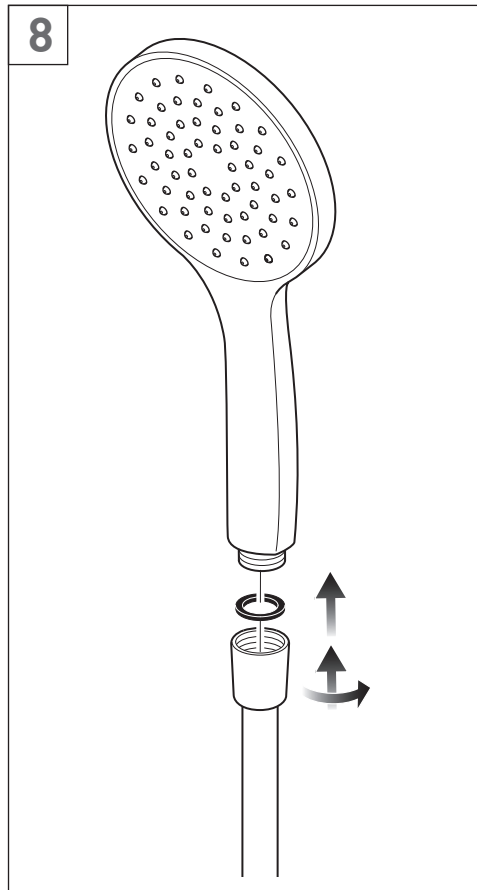
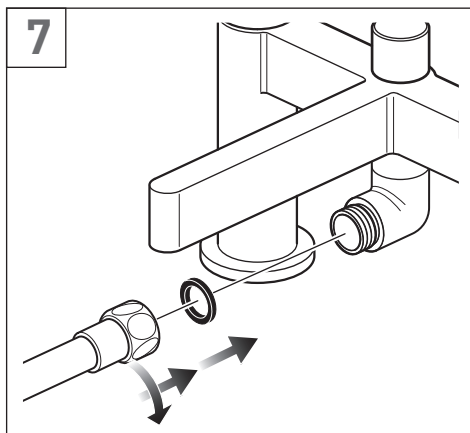
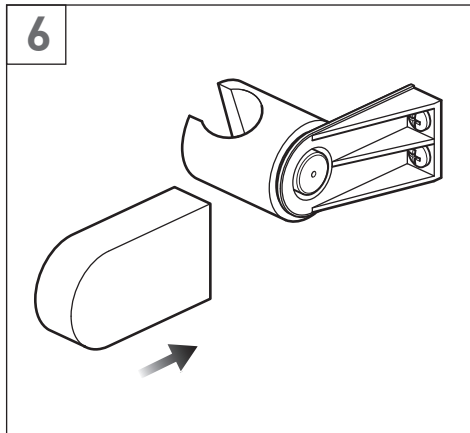
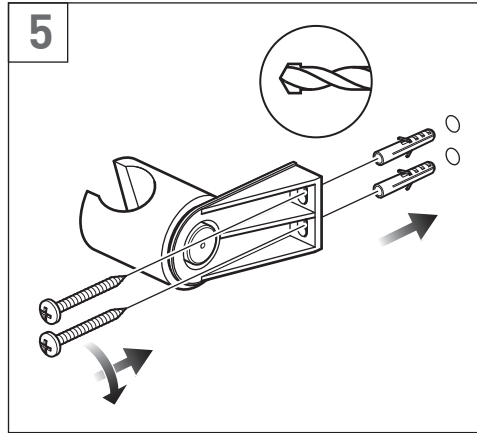
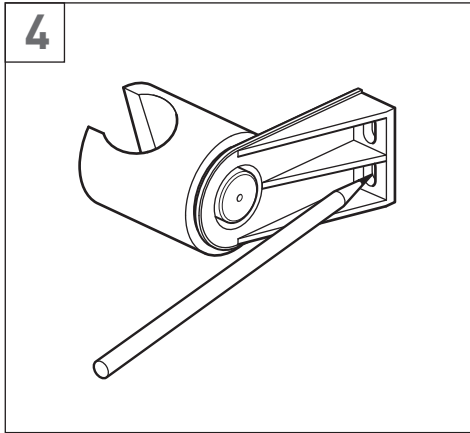

Installation

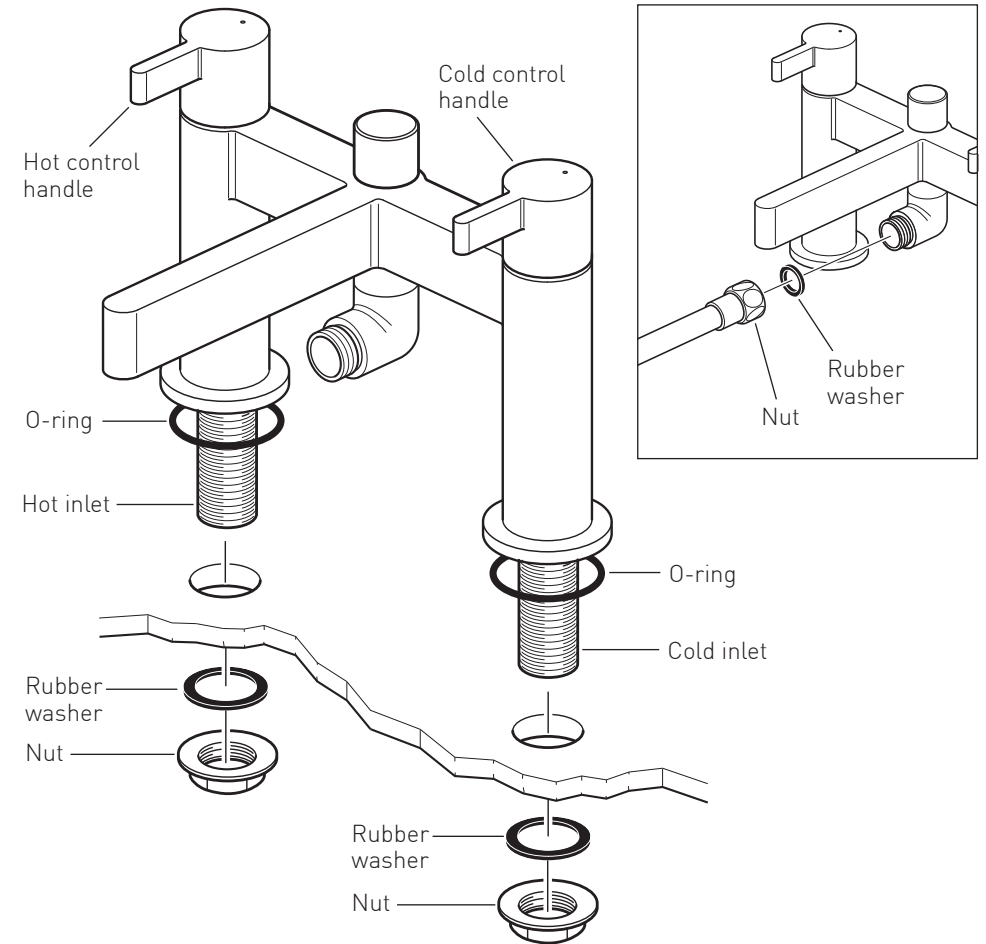

Before installing your new mixer, flush through the pipework to ensure removal of debris, turn off the water supply.

Position both O-rings into the bottom of the mixer body.

Position the mixer on the bath. From the underside of the bath fit the rubber washers and nuts. Tighten the nuts to clamp the mixer to the bath.

CAUTION: Do not over tighten the nuts as this may damage the bath.

Connect the water supply to the inlet pipes. The hot water should be connected to the left hand pipe and cold to the right.

Place a rubber washer into the nut end of the hose and attach it to the mixer outlet.

Installation

Handset holder

⚠ Warning! Please check for any hidden pipes and cables before drilling holes in the wall.

If you are fitting the unit to a partition wall or a wall of particularly soft substrate you will need specialist fixings.

Select the position for the shower holder bracket and mark the 2 fixing positions with a suitable pencil.

Remove the holder from the wall.

Suitably fix the holder to the wall using appropriate fixings.

Finally slide the cover onto the holder.

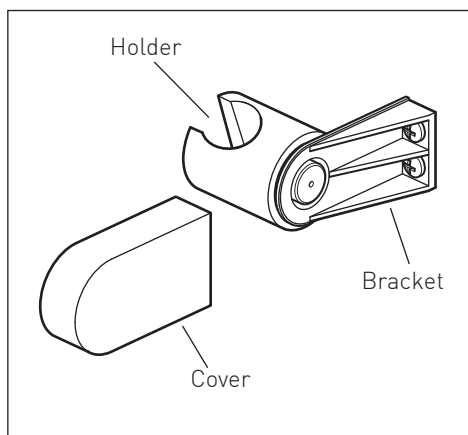
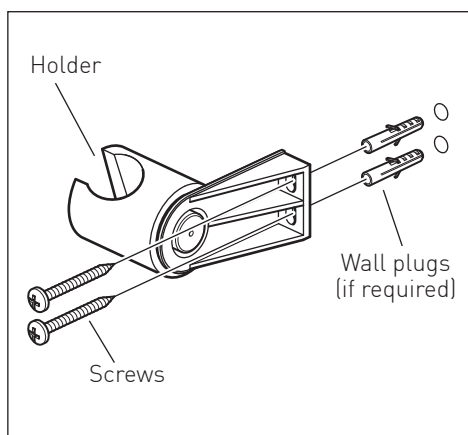
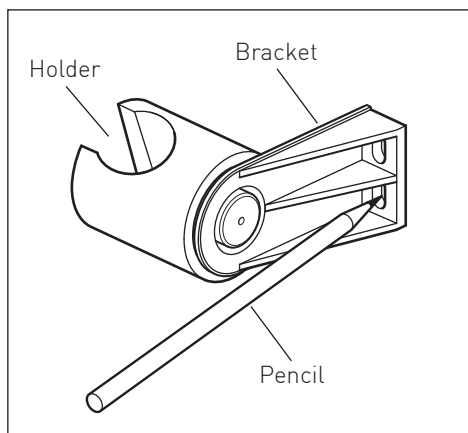

Installation

Handset

Place one of the rubber washers into the cone end of the hose and screw to the Showerhead.

Place the handset into the holder.

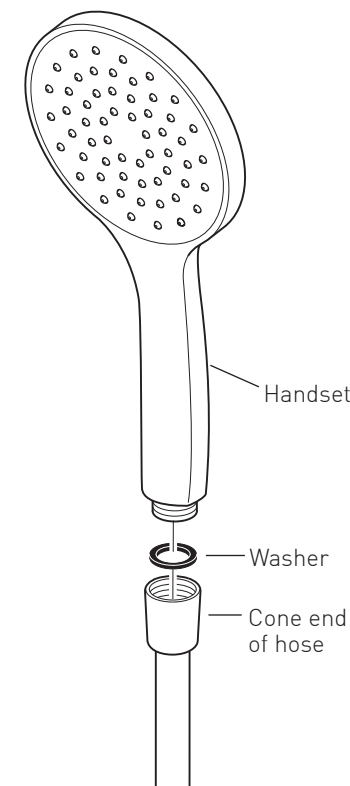

Notes:

Notes: