



where inspiration flows

# ORA

Installation Guide  
Multi Function Slide Rail Shower Kit with Outlet



This instruction booklet covers model:  
ORA-MFSRKWO-RO-CP

ORA-MFSRKWO-RO-CP

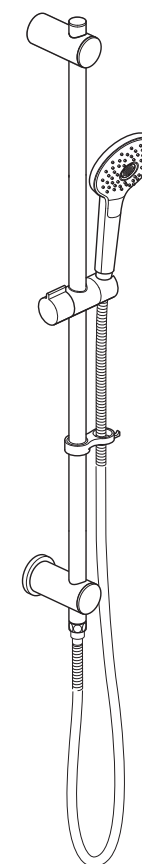

Vado  
Wedmore Road, Cheddar, Somerset, England BS27 3EB  
tel 01934 744466 fax 01934 744345  
aftersales@vado.com  
www.vado.com



## Important - please read

Please read these instructions carefully before starting installation and keep for future reference.

Remove all packaging and check the product for missing parts or damage before starting installation.

Any alterations made to this product and fittings may infringe water regulations and will invalidate the guarantee.

The installation must comply with all Local/National Water Supply Authority Regulations/Byelaws and Building and Plumbing Regulations.

To be installed in accordance with BS EN806.

We strongly recommend that you use a qualified and registered plumber.

## General installation

When installed, the fitting must comply with the requirements of the Water Supply (Water Fittings) Regulations 1999 and Scottish Byelaws 2004.

For further information, contact the Water Regulations department of your local water supplier (see the WRAS website [www.wras.co.uk](http://www.wras.co.uk) for details) or the Water Regulations Advisory Scheme by email ([info@wras.co.uk](mailto:info@wras.co.uk)) or telephone: 01495848454.

The fitting of an isolating valve to the inlet feed is advised for ease of maintenance.

Please take great care when installing this product not to damage its surface.

Please note if installing in an enclosed environment, access should be left for servicing and maintenance. No costs relating to inadequate access can be accepted.

## Contents of Packaging

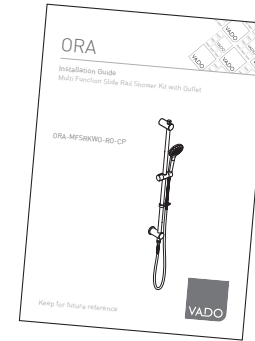

**Installation guide & User manual**

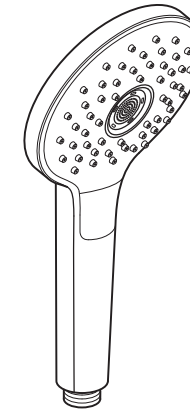
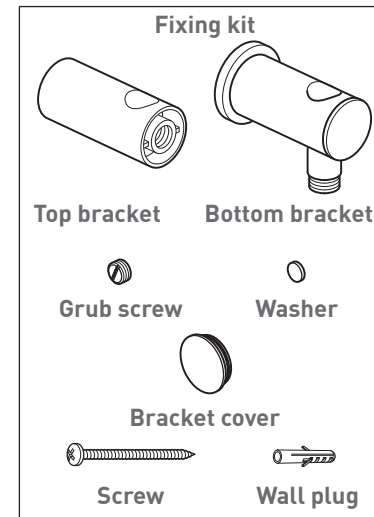

**Handset**

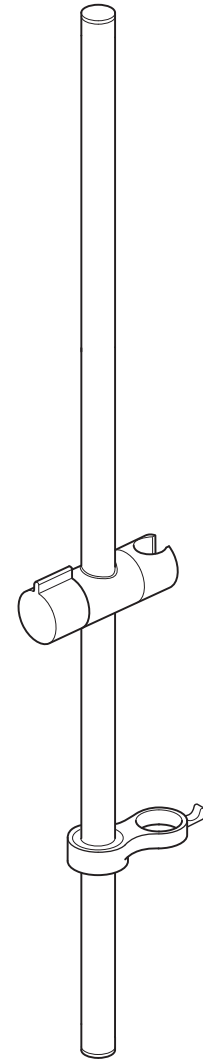

**Slide rail**

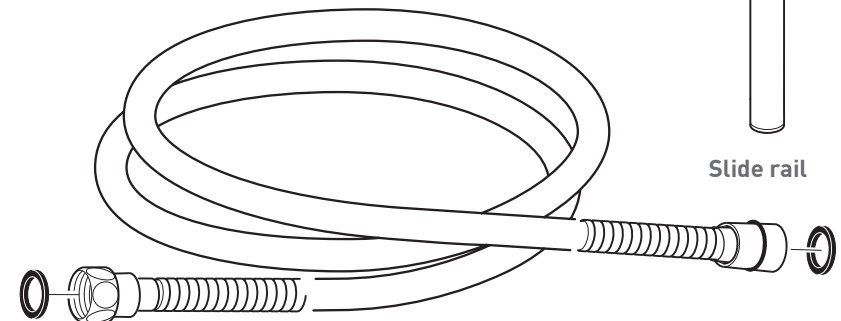

**Shower hose with 2 washers**

# Dimensions

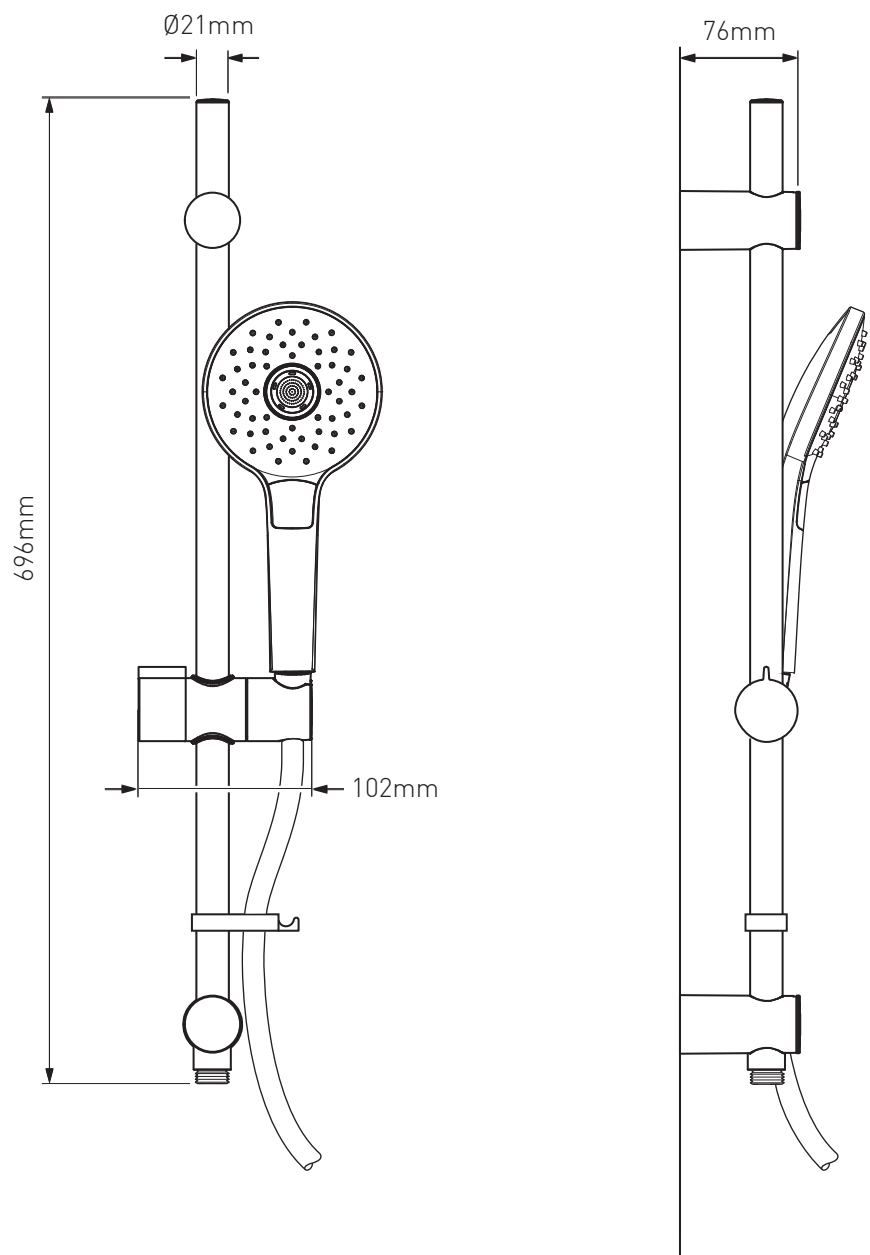

# Installation - Quick guide

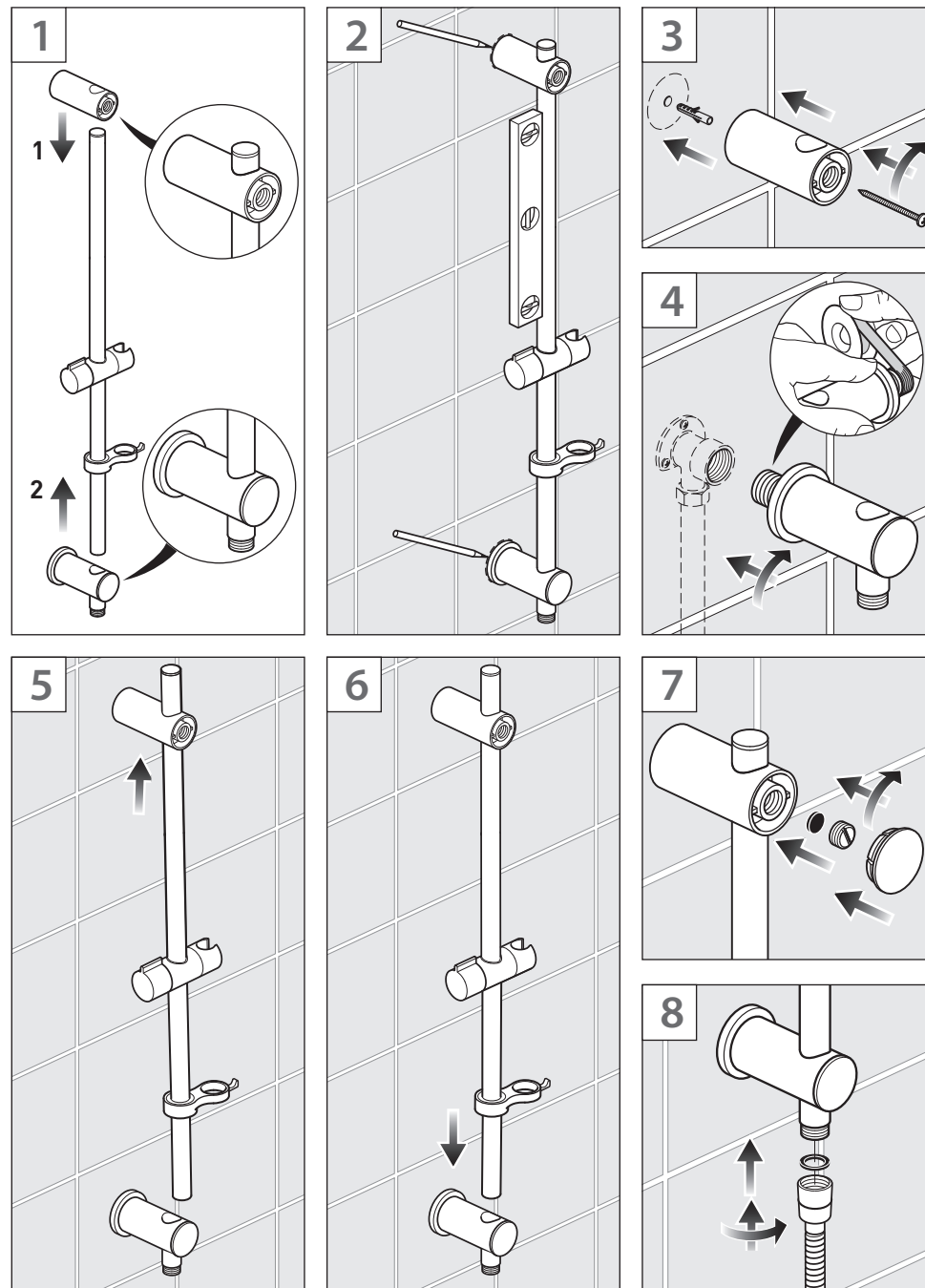

# Installation

**Please Note:** before installing the rail you will need to prepare the wall with a ½" flush connector (not supplied), at the position of the bottom bracket.

Bear in mind the different heights of people likely to use the shower.

Connect the water supply from the valve.

Check for leaks, and finish off the wall.

**Warning!** Please check for any hidden cables and pipes before drilling holes in the wall.

Screw the bottom bracket temporarily into the flush connector with the outlet pointing downwards.

Slide the top bracket onto the rail leaving 20mm of rail sticking through the bracket.

Place the bottom of the rail into the hole on in the top of the bottom bracket.

Make sure that the rail is vertical using a level. Mark the wall to indicate the position of the top bracket.

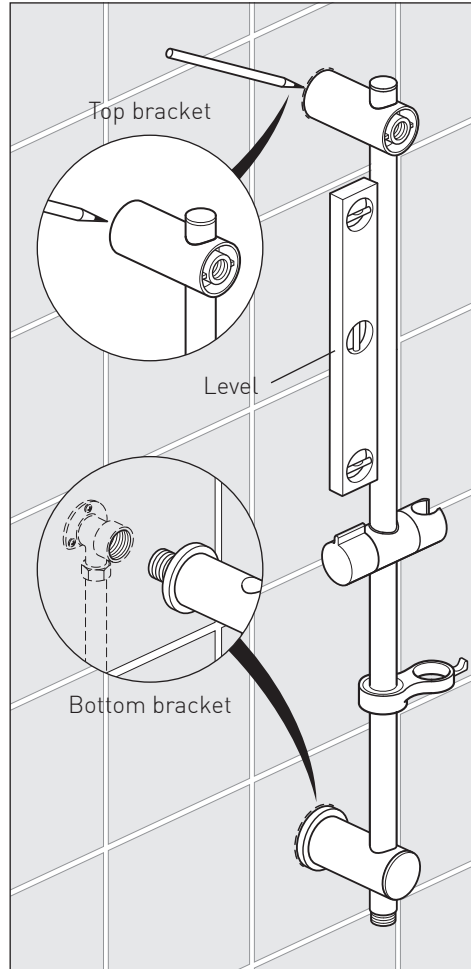

## Top bracket

Using a 6mm drill bit for the wall plug, drill the wall at the centre of the marked position.

**Note:** If fixing through tiles use masking tape to stop the drill from slipping and push the head of the plug in through pass the tile.

Fix in position using the supplied wall plugs and screws.

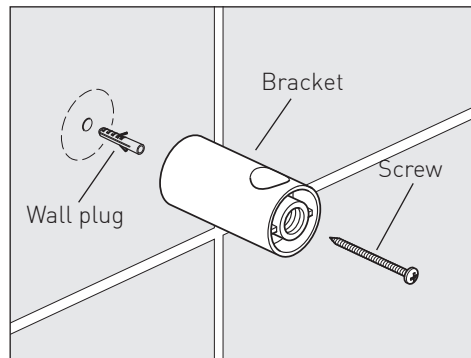

# Installation

Using PTFE tape on the thread of the bracket screw into the connector.

Make sure that the outlet is pointing downwards.

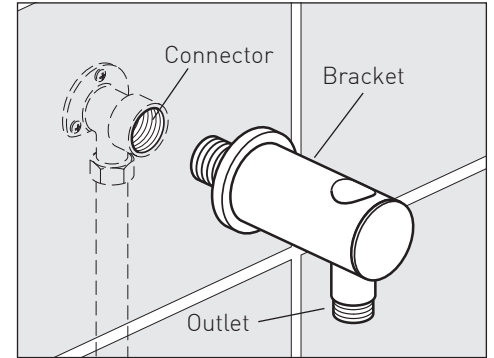

Slide the rail up through the top bracket (the bracket will need to be rotated slightly) until it fits on the top of the bottom bracket. Then push the rail down into the bottom bracket.

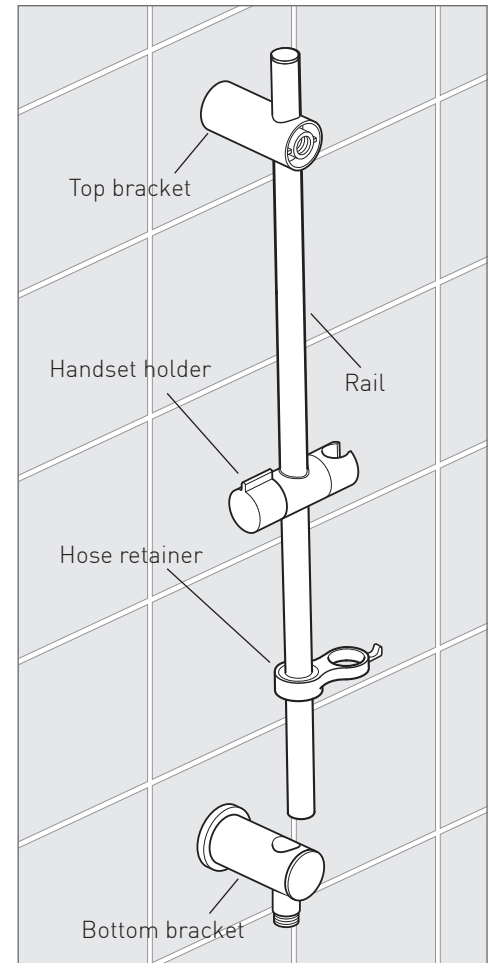

## Installation - Shower hose

Top bracket only.

Push a rubber insert into the hole of the bracket, screw in the grub screw and tighten.

Push on the cover.

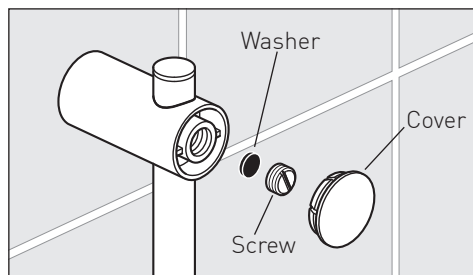

### Shower hose

Push the cone end of the hose up through the hose retainer.

### Handset

Place one of the rubber washer into the cone end of the hose and screw to the handset.

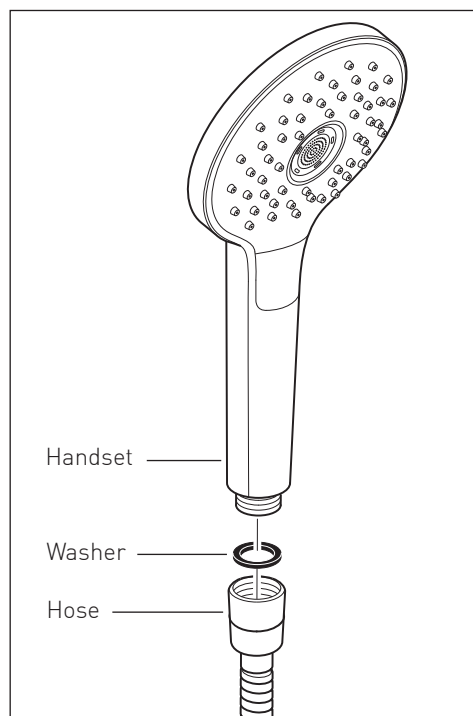

Place the second rubber washer into the nut end of the hose and attach it to the outlet on the bottom bracket.

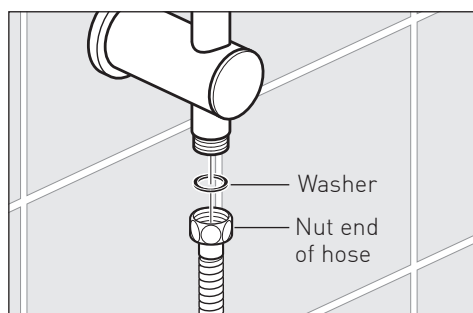

## Operation

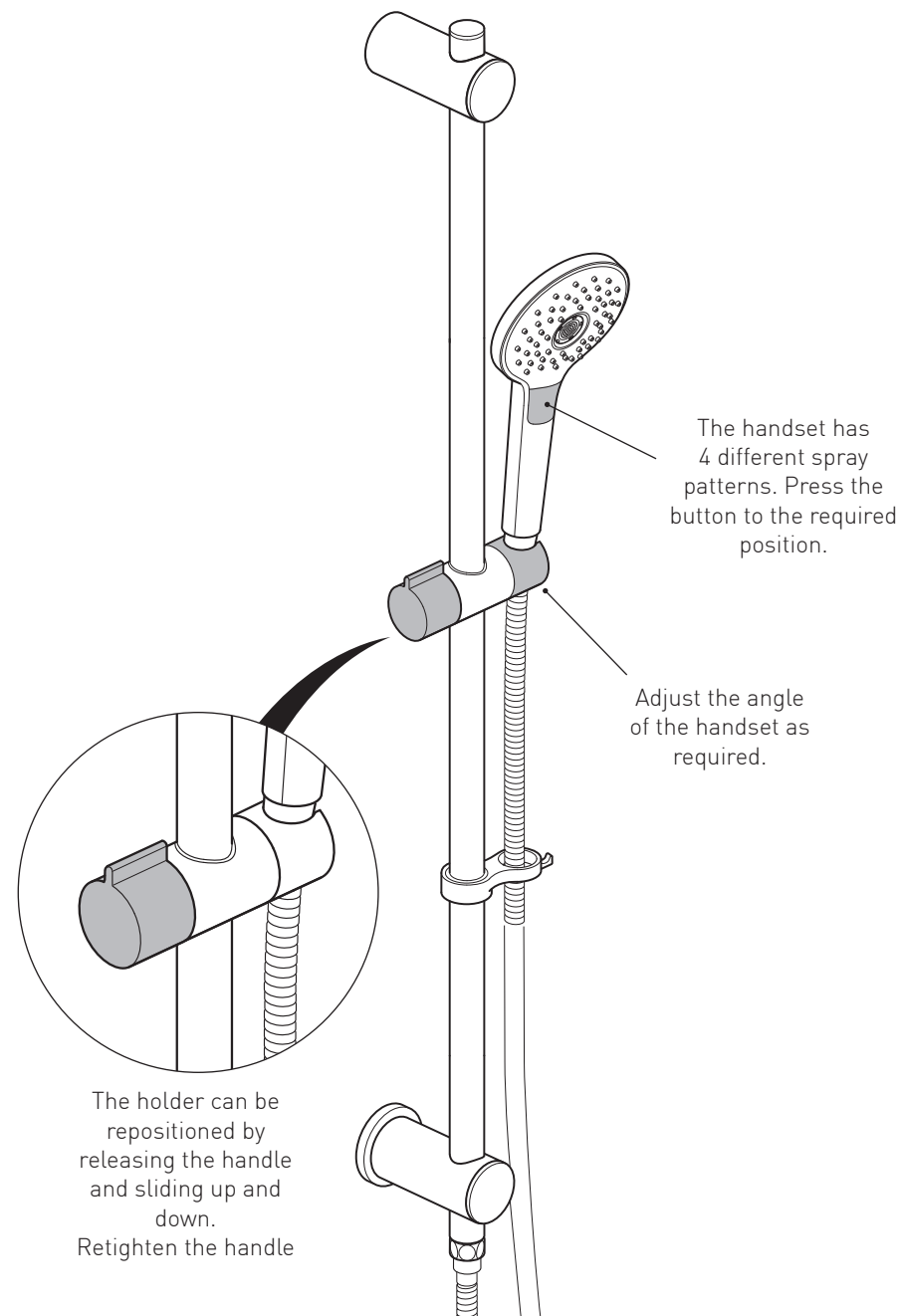

## Cleaning instructions

The electroplating on this product is finished to the highest standard. Due care needs to be taken to ensure the appearance is retained.

We recommend cleaning all products with a soft damp cloth **ONLY** and advise strongly against the use of all aggressive/corrosive cleaning products i.e. powders and liquids. If these instructions are not followed, this may invalidate your guarantee in the event of a problem occurring.

## Guarantee

All VADO products come with a 2 year guarantee as standard. Within this guarantee period VADO will provide replacement parts and any labour **[SEE NOTE 1]** needed to complete the product repair.

This standard guarantee may be extended by registering your product to give up to a 15 year guarantee period. Once registered:

VADO chromed brassware and stainless steel products have a 15 year guarantee (2 years parts and labour plus 13 years parts only).

VADO Sensori SmartTouch and SmartDial products have a 5 year guarantee (parts and labour).

VADO Identity and i-tech products have a 5 year guarantee (2 year parts and labour plus 3 years parts only).

All other VADO products have a 3 year guarantee (2 years parts and labour plus 1 year parts only)

### **[SEE NOTE 2].**

#### **Guarantee Conditions**

Our products are guaranteed against manufacturing defects from the date of purchase until the expiry of the relevant guarantee period shown above.

The guarantee is only valid if:

- The product has been installed, used and maintained in accordance with VADO's instructions and subjected to normal use only.
- The defect is not due to use of an unsuitable or inadequate water or power supply.
- The defect is not due to accident, misuse, neglect or incorrect/inappropriate repair (other than by VADO or VADO authorised agents) or damage caused by foreign objects or substances.
- The extended guarantee is only available if you have completed the Guarantee Registration Process. This can be done via the VADO website or via phone to our aftersales team.

Registration must be completed within 6 months from date of purchase.

Under the extended guarantee period VADO will, at its option, offer to supply any replacement product (or component part) assessed to be defective **[SEE NOTE 3].**

The guarantee (whether standard or extended) is non-transferable to any subsequent owner. All claims under the guarantee should be notified in the first instance to our Aftersales department, contact details below, this must be done no later than the last day of the relevant guarantee period.

All claims must be accompanied by proof of purchase (sales receipt or delivery note) from an official VADO dealer.

The guarantee does not extend to any consequential loss or damage.

After repair or replacement, the relevant guarantee period will be calculated from the original date of purchase.

VADO operates a policy of continuous product development and therefore reserves the right to change the product, packaging and documentation specifications without notice. E&OE.

#### **NOTES:**

**[1]** Labour via our engineer network is only available in the UK. Attendance by a VADO engineer or sub-contract engineer will be under our standard terms and conditions.

**[2]** VADO spare parts and shower hoses are under a parts only guarantee.

**[3]** VADO reserves the right to charge in advance for a product (or replacement part) pending collection and investigation (at VADO expense) to confirm a defect is due to a manufacturing issue. If a defect is found the charge will be refunded or cancelled.

This guarantee is in addition to and does not affect your statutory rights as a consumer.

Tel: 01934 745163

Email: [aftersales@vado.com](mailto:aftersales@vado.com)