

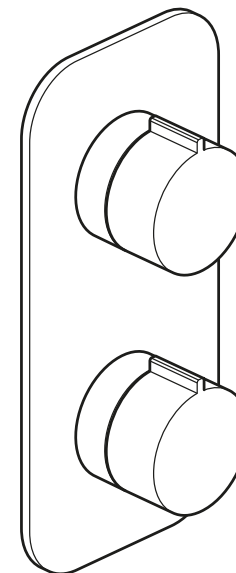

INDIVIDUAL
by VADO



ALTITUDE

1 way thermostatic shower valve

—

VADO
Wedmore Road, Cheddar,
Somerset, England BS27 3EB
tel 01934 744466
fax 01934 744345
www.vado.com
sales@vado.com

Version 1, 1-6-2021

INSTALLATION GUIDE

INDIVIDUAL
by VADO

Important - please read

Please read these instructions carefully before starting installation and keep for future reference.

Remove all packaging and check the product for missing parts or damage before starting installation.

Any alterations made to this product and fittings may infringe water regulations and will invalidate the guarantee.

The installation must comply with all Local/National Water Supply Authority Regulations/Byelaws and Building and Plumbing Regulations.

To be installed in accordance with BS EN806.

We strongly recommend that you use a qualified and registered plumber.

General installation

This fitting is a mixing device and therefore water supplies should be reasonably balanced.

When installed, the fitting must comply with the requirements of the Water Supply (Water Fittings) Regulations 1999 and Scottish Byelaws 2004.

For further information, contact the Water Regulations department of your local water supplier (see the WRAS website www.wras.co.uk for details) or the Water Regulations Advisory Scheme by email (info@wras.co.uk) or telephone: 01495848454.

Before making any inlet pipe connections, all supply pipes MUST be thoroughly flushed to remove debris. Failure to do so could result in damage or low flow from the mixer unit.

The fitting of isolating valves to the inlet feeds is advised for ease of maintenance.

Please take great care when installing this mixer not to damage its surface.

Please note if installing in an enclosed environment, access should be left for servicing and maintenance. No costs relating to inadequate access can be accepted.

Operating Specifications

Operating Pressure

Minimum operating pressure **0.2 bar** (**1 bar** if used as a bath fill)

Maximum operating pressure **5 bar**

Contents of Packaging

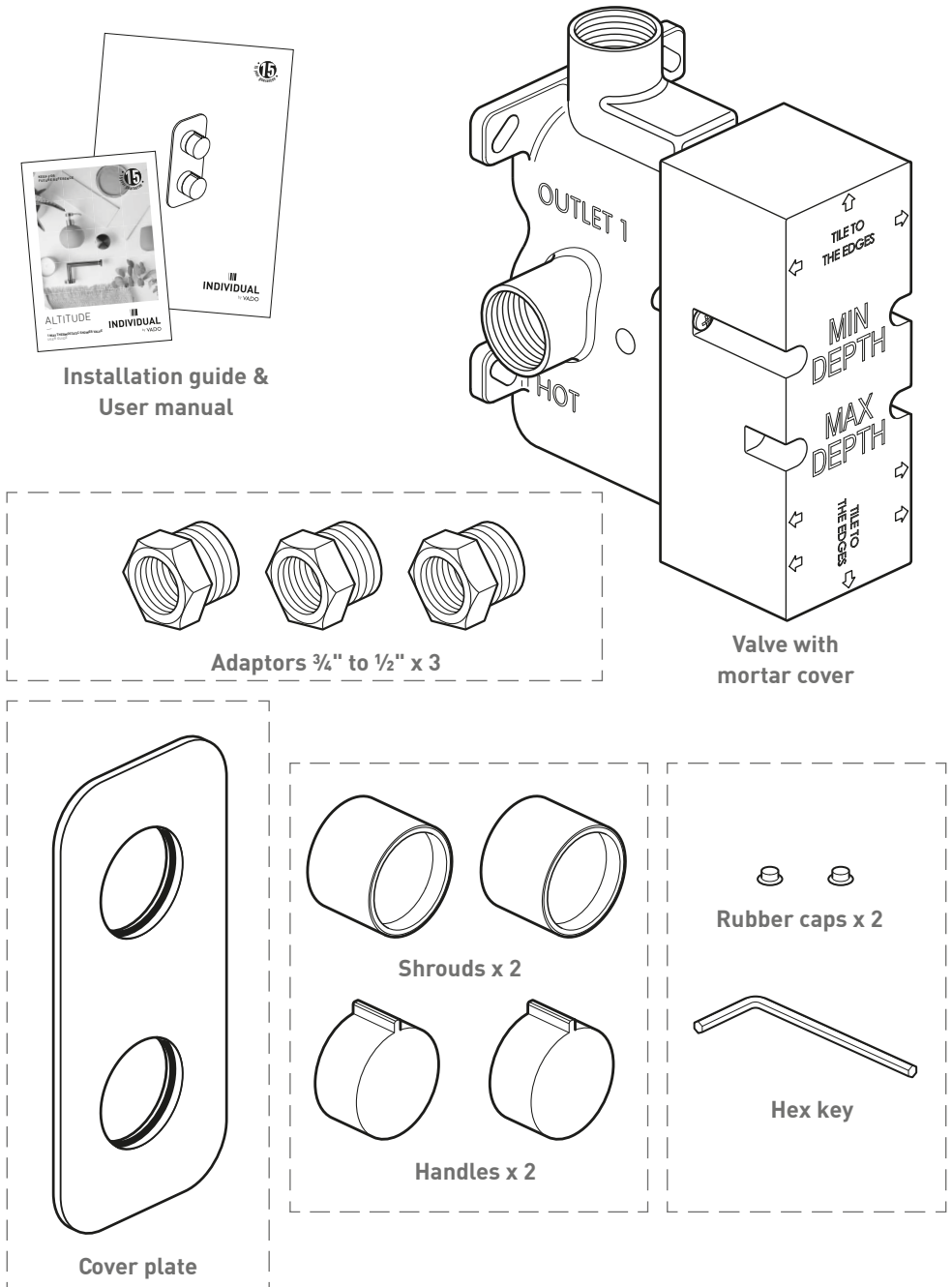

Dimensions

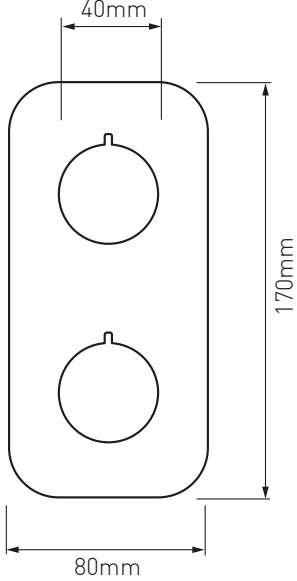
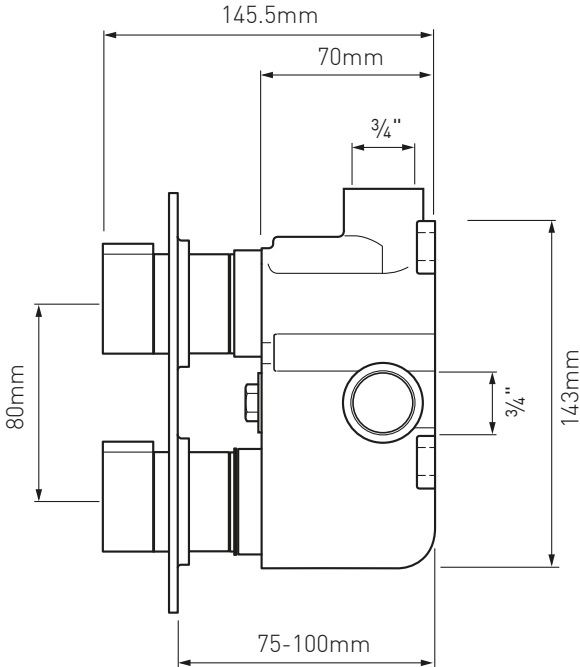

Installation - Quick guide

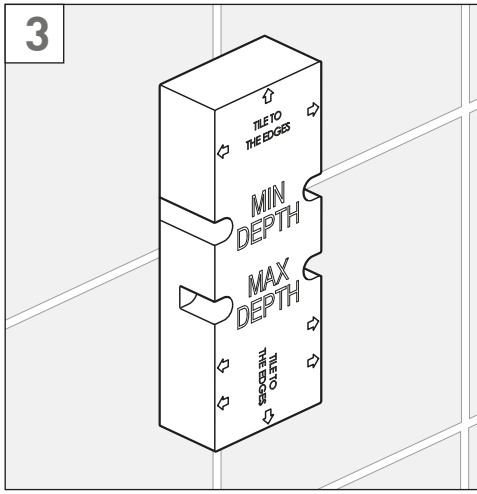
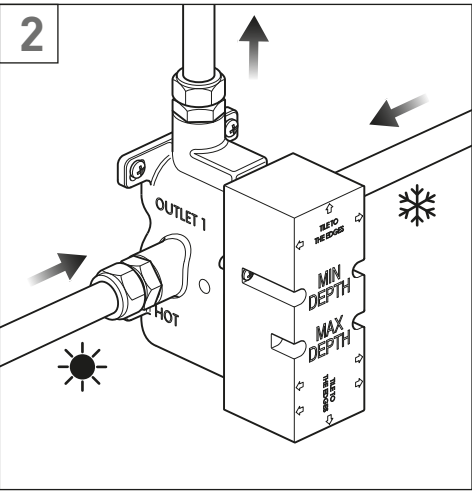
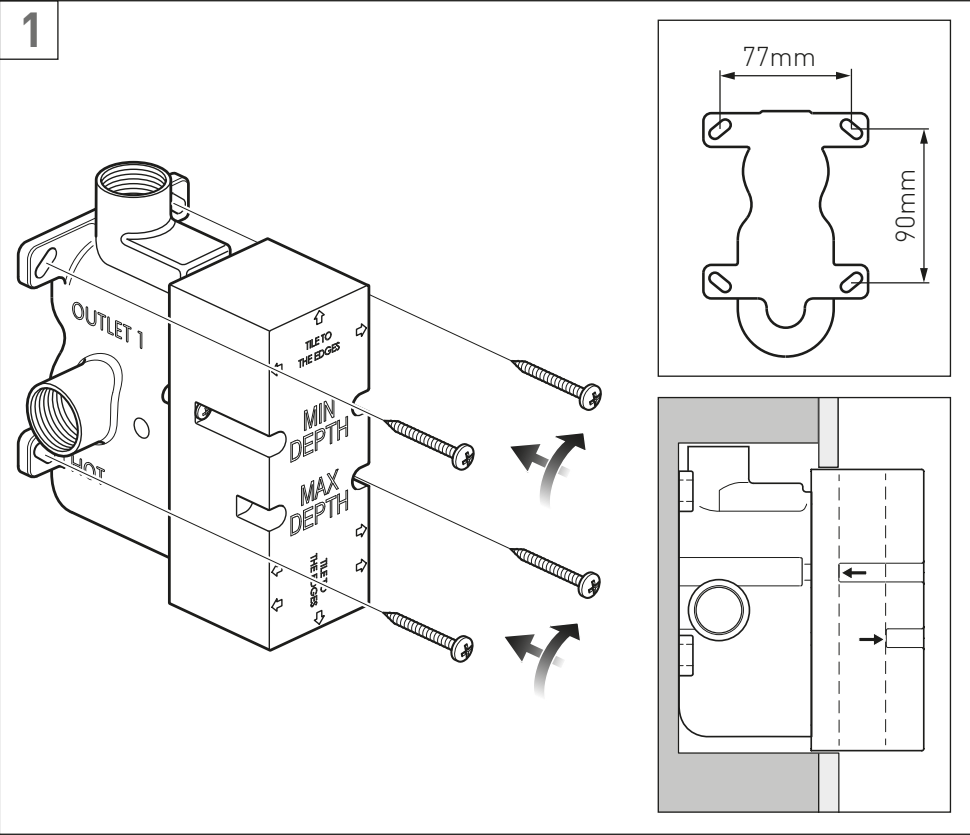

Installation - Quick guide

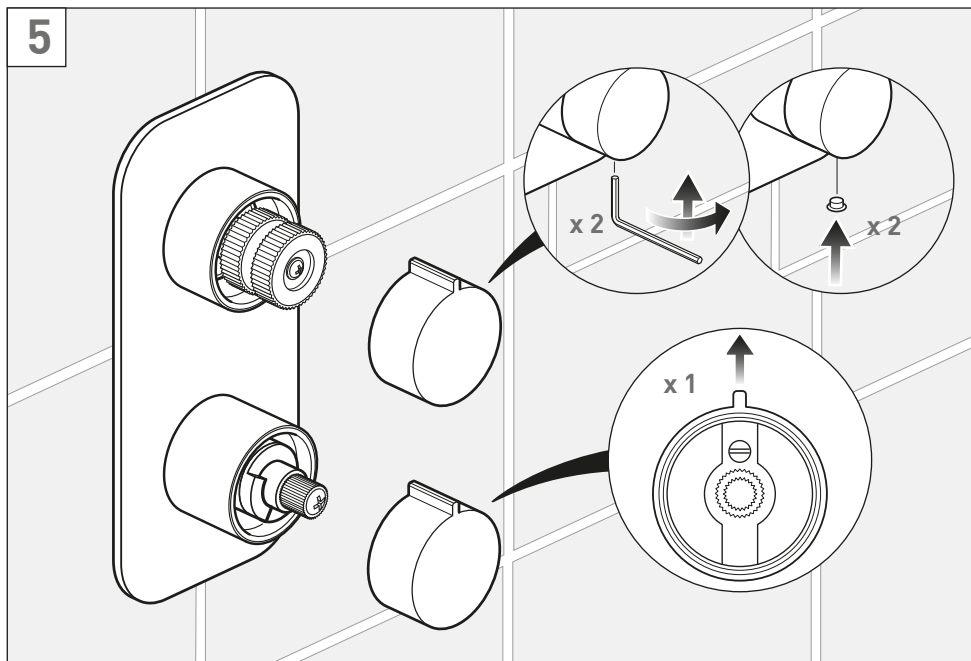
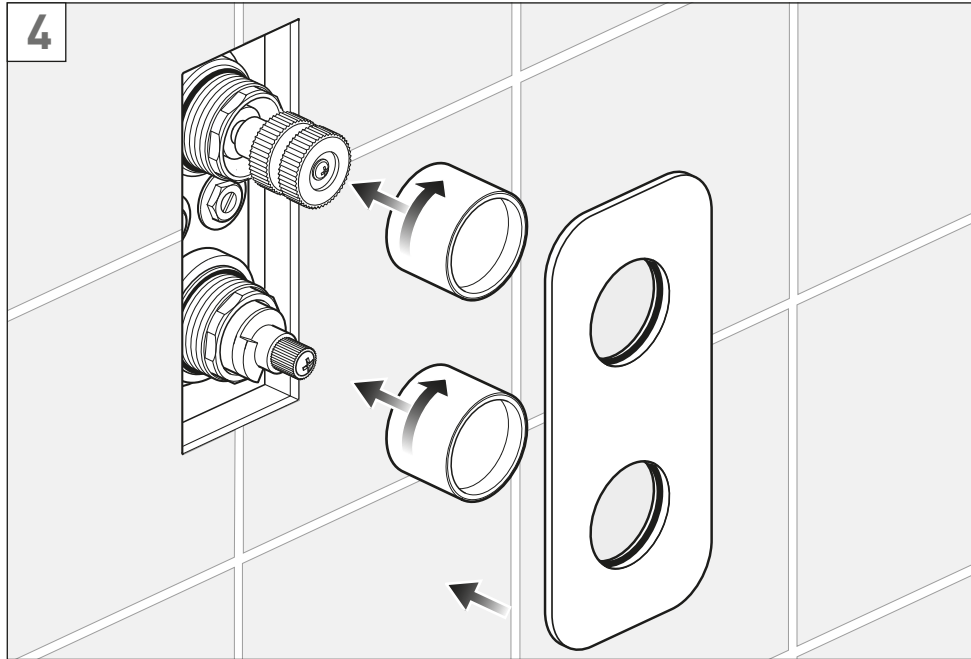

Installation

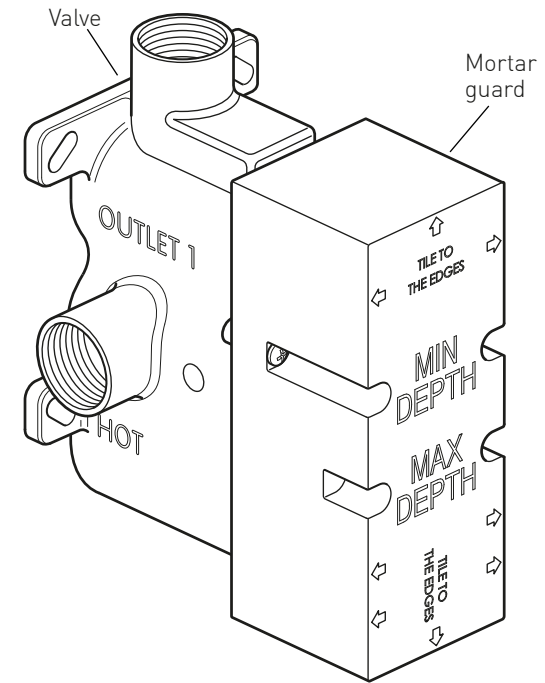

Rinse pipe work thoroughly before fitting the valve.

Warning! Please check for any hidden cables and pipes before drilling holes in the wall.

The valve must be set into the wall between (75mm minimum – 100mm maximum) If you are fitting the valve to a partition wall or a wall of particularly soft substrate you will need specialist fixings.

Mortar guard

During and after installation protect the outer parts by leaving the mortar guard on the valve to avoid damage to plated surfaces.

Installation

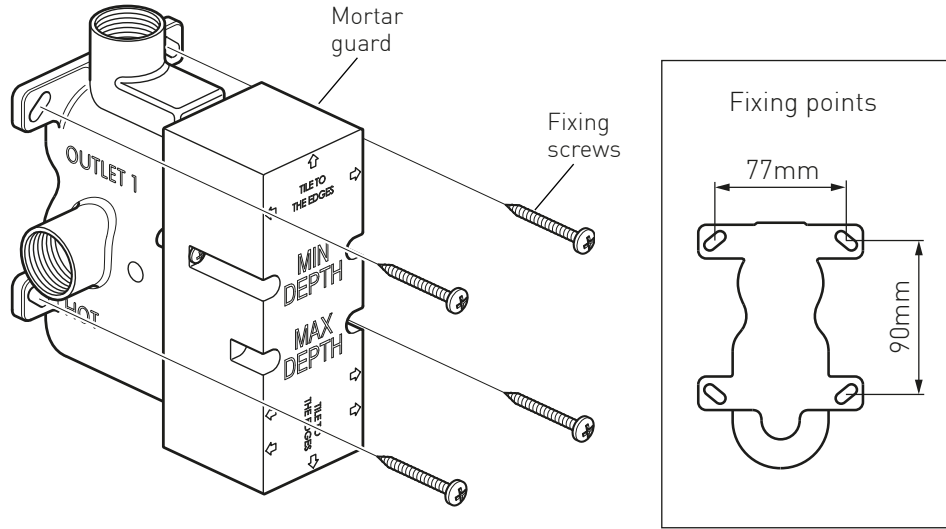

Select the position for the shower valve and offer the shower valve to the wall, make sure the valve is vertical with a level and mark the 4 fixing points with a suitable pencil, see above right for dimensions. Remove the shower valve from the wall, drill the holes to a suitable depth for the wall plugs and secure with suitable screws.

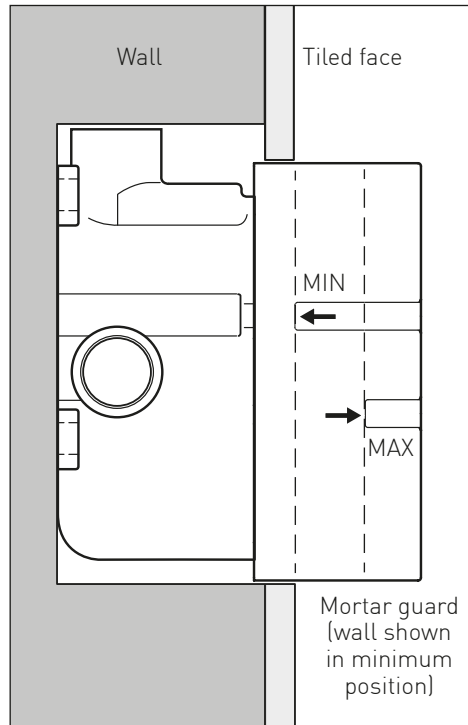

Installation

Connect hot supply to the lower left inlet of the valve and cold supply to the lower right inlet. Connect the outlet to the desired channel e.g. shower or handset.

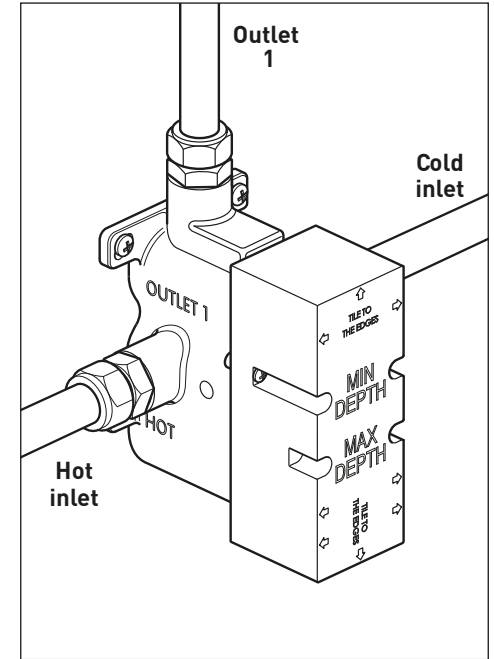

Finish the wall by tiling up to the mortar guard, keep the final finished wall surface between the min and max marks.

Unscrew the 2 mortar guard screws and remove from the wall.

Your valve is now ready to be commissioned. Please refer to page 11 to ensure your valve is calibrated.

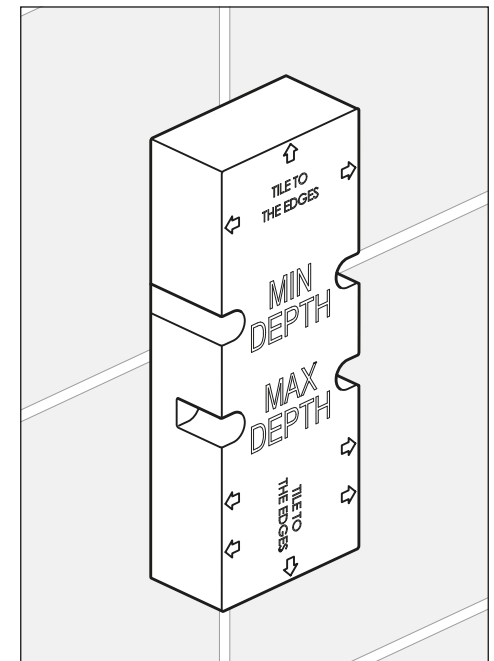

Installation

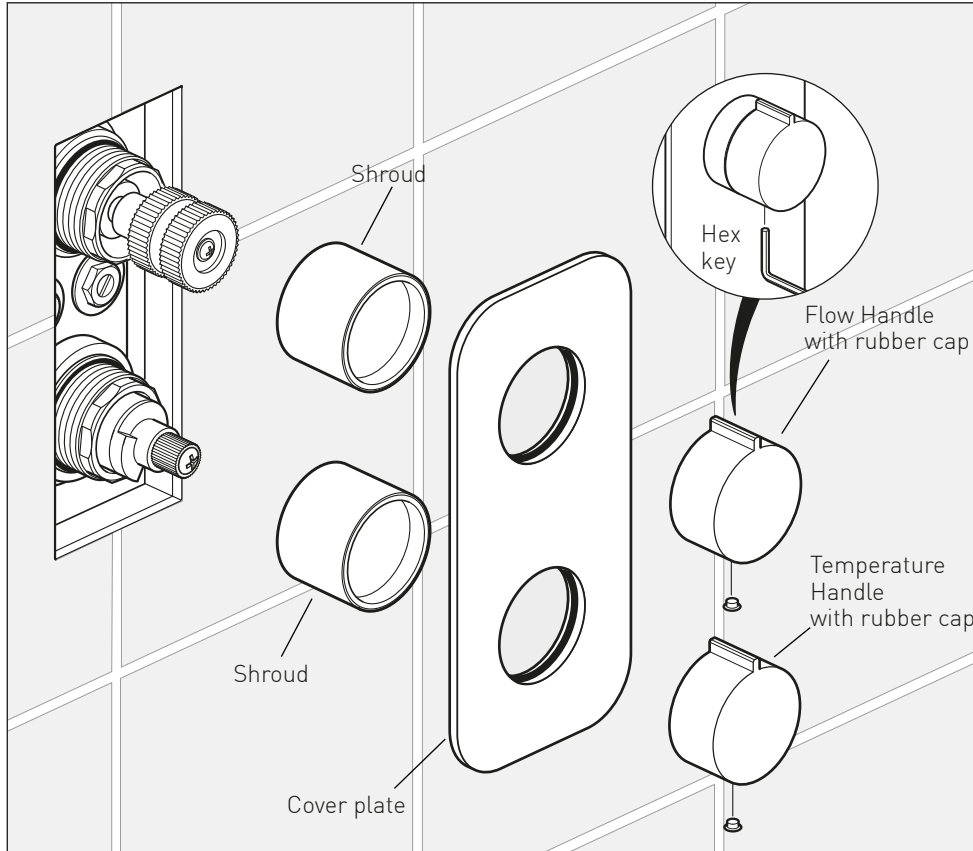

Screw the shrouds onto the valve.
Guide the cover plate over the shrouds and up to the wall being careful not to dislodge or damage the seal. Apply a thin bead of silicone around the outside to seal against the tiled surface.

Temperature handle (bottom)

Ensure the temperature handle is correctly located with the handle stop at 12 o'clock (see right). Carefully slide the handle on the splines, secure with the grub screw and insert rubber cap in hole.

Flow handles (top)

With the handle pointing up in the off position carefully slide onto the splines, secure with the grub screw and insert rubber cap in hole.

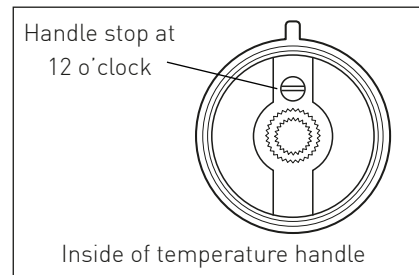

Temperature commissioning

The valve has been factory set under balance pressures and hot water supply at 65° C. When your specific operating conditions are significantly different from the above, the temperature of the water may vary from the setting.

When the difference is too great, you can adjust the calibration of the valve to suit individual requirements of the installation:

1. Check the temperature of the water being delivered to the outlet with a thermometer.
NOTE: temperature readings should be taken at normal flow rate after allowing for the system to stabilise.

2. If the temperature is not 38° proceed to reset the calibration as follows:

Do not remove the plastic stop ring. Turn the spline of the valve clockwise to decrease the temperature and anti-clockwise to increase the temperature until 38° is achieved at outlet.

3. Ensure that the stop on the stop ring is at 10 o'clock.

When the handle is attached (see page 10) ensure the temperature does not exceed 46° when turned entirely anti-clockwise.

Your valve setting is now commissioned.

