

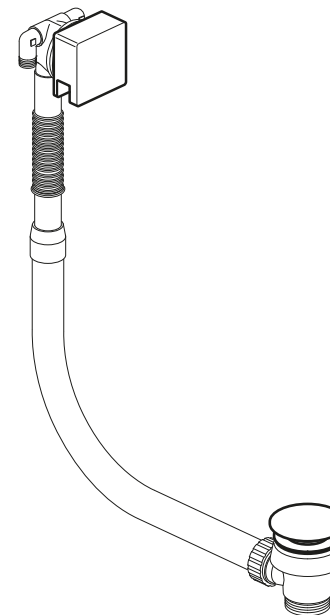

INDIVIDUAL
by VADO



OMIKA NOIR

Push type bath filler waste + overflow

—

VADO
Wedmore Road, Cheddar,
Somerset, England BS27 3EB
tel 01934 744466
fax 01934 744345
www.vado.com
sales@vado.com

Version 1, 1-7-21

INDIVIDUAL
by VADO

Important - please read

Please read these instructions carefully before starting installation and keep for future reference.

Remove all packaging and check the product for missing parts or damage before starting installation.

Any alterations made to this product and fittings may infringe water regulations and will invalidate the guarantee.

The installation must comply with all Local/National Water Supply Authority Regulations/Byelaws and Building and Plumbing Regulations.

To be installed in accordance with BS EN806.

We strongly recommend that you use a qualified and registered plumber.

General installation

When installed, the fitting must comply with the requirements of the Water Supply (Water Fittings) Regulations 1999 and Scottish Byelaws 2004.

For further information, contact the Water Regulations department of your local water supplier (see the WRAS website www.wras.co.uk for details) or the Water Regulations Advisory Scheme by email (info@wras.co.uk) or telephone: 01495848454.

Please take great care when installing this product not to damage its surface.

Please note if installing in an enclosed environment, access should be left for servicing and maintenance. No costs relating to inadequate access can be accepted.

Contents of Packaging

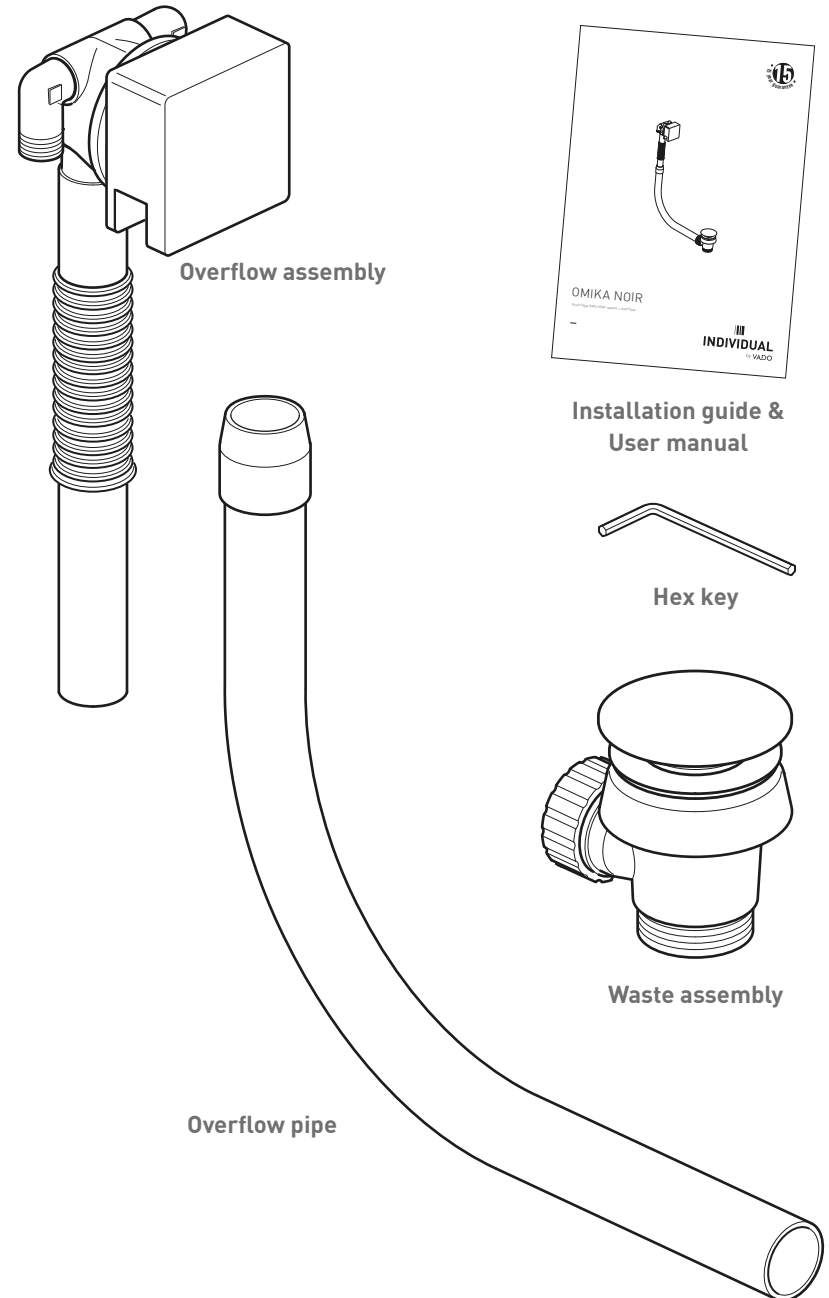

Valve dimensions

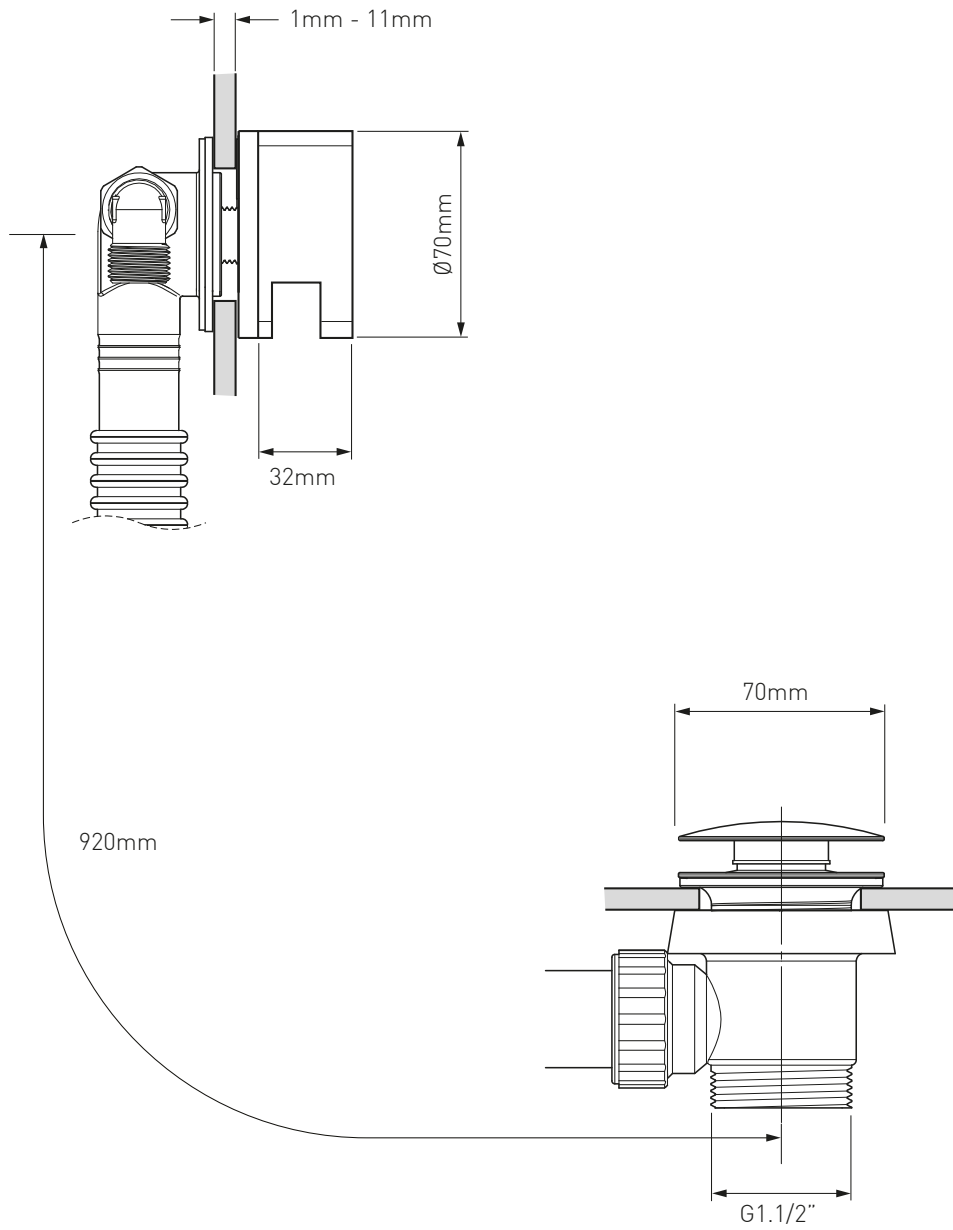

Installation - Quick guide

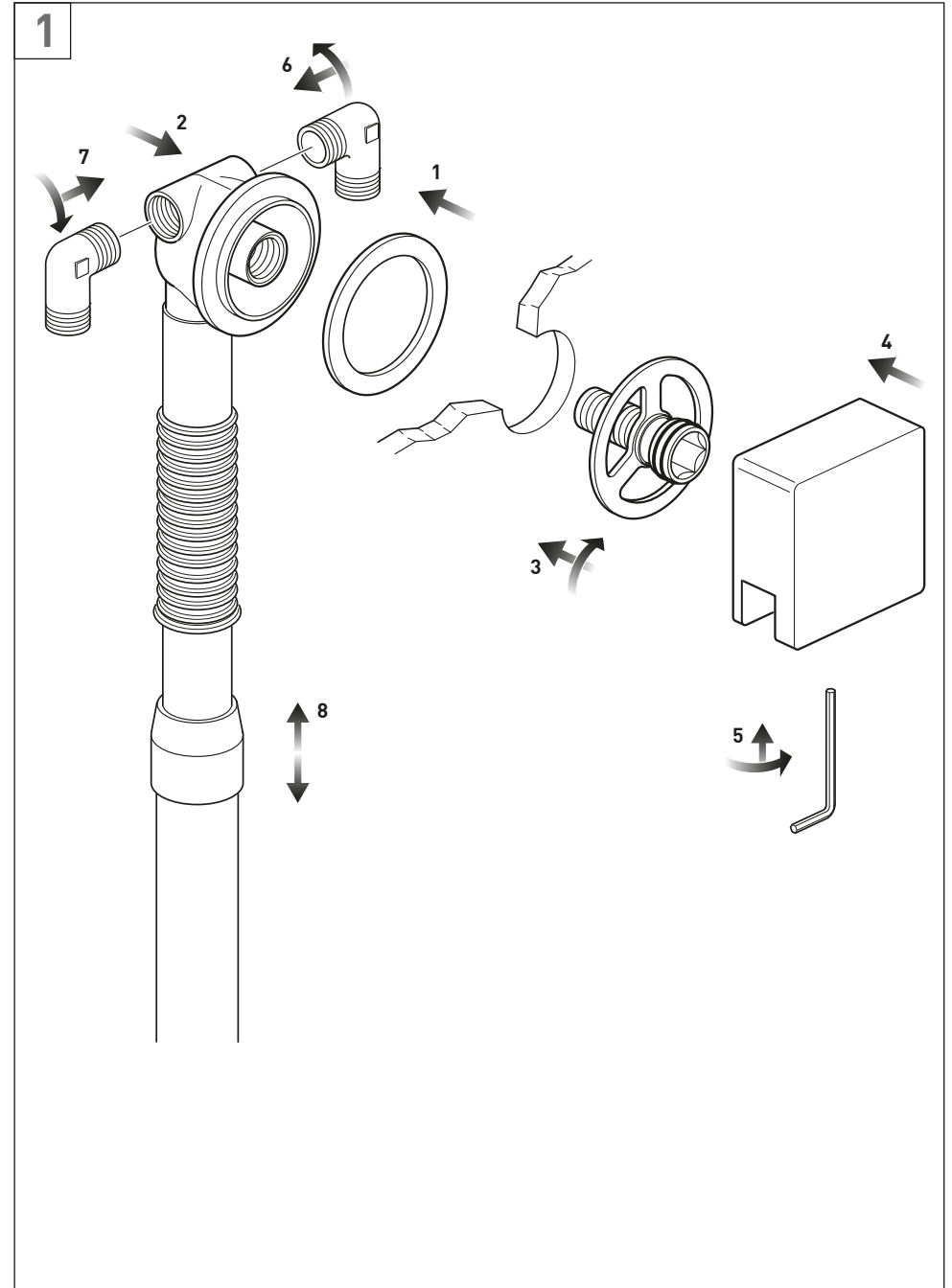

Installation - Quick guide

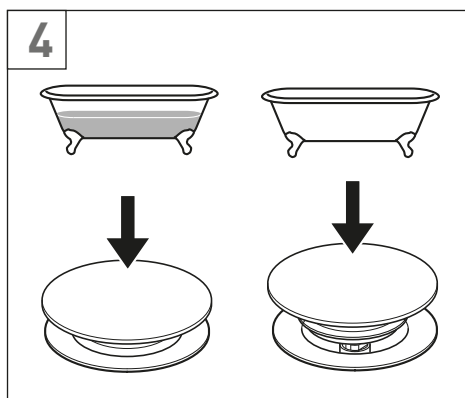
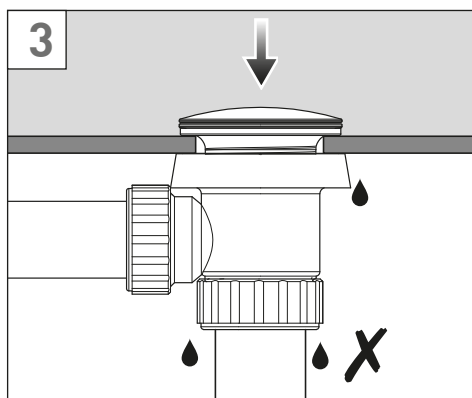
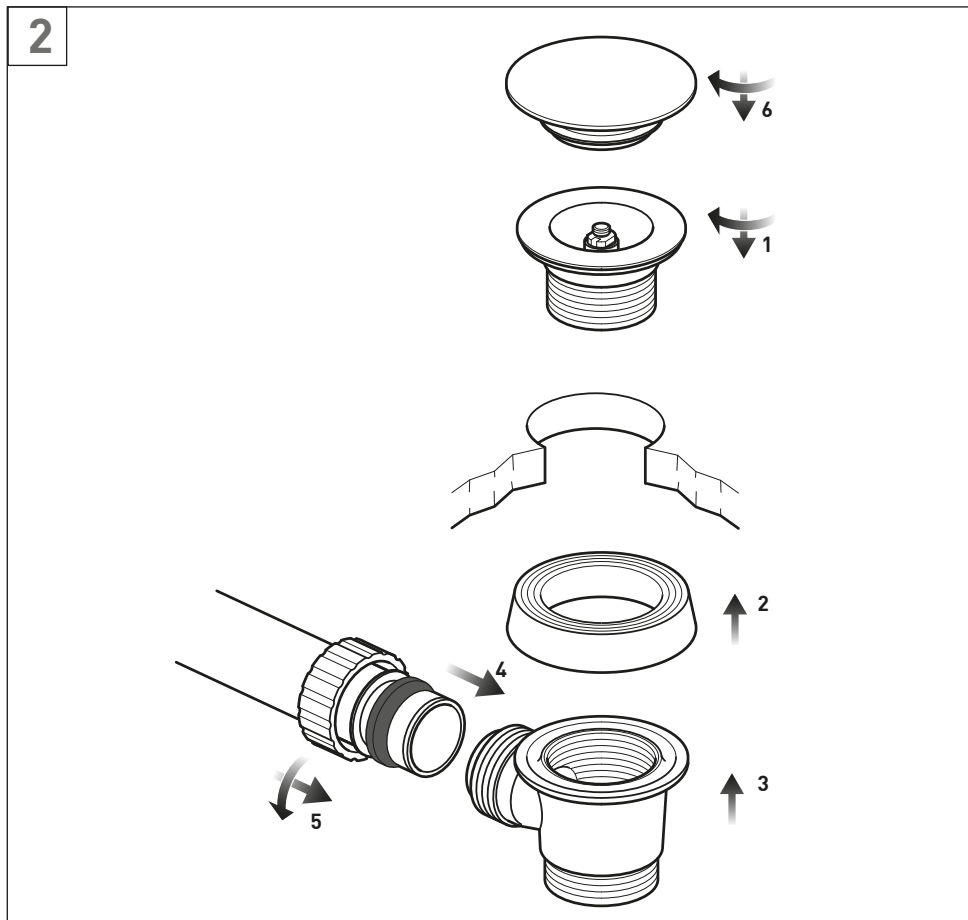

Installation

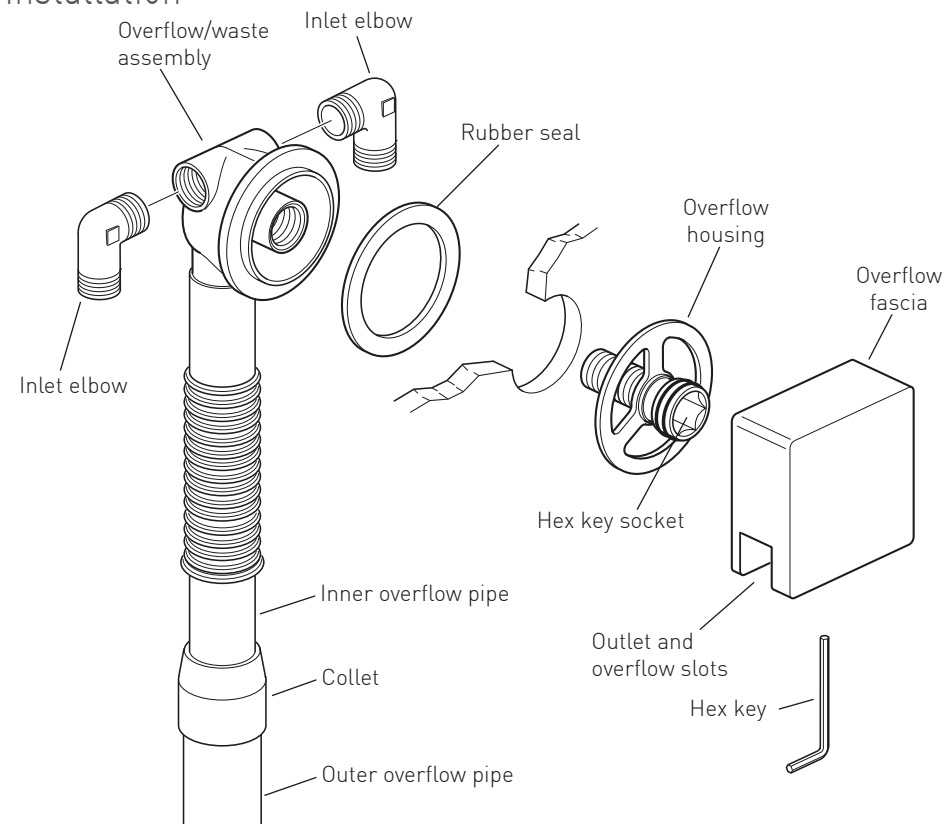

The length of the overflow pipe can be adjusted by pulling apart or pushing together the inner and outer overflow pipes.

Should you need to reduce the length even more, pull the outer overflow out of the collet, cut both the outer overflow pipe and the inner overflow pipe to the required length, remove any burrs and reassembly.

Ensure all calculations are correct before cutting pipes.

Remove the blanking plug(s) from the overflow assembly. Using PTFE tape fit the inlet elbow(s).

Push the rubber seal onto the overflow/waste assembly, and from the outside hold in place over the bath overflow hole.

Screw on the overflow housing, tighten with an hex key.

Caution: do not overtighten as this may damage the parts and/or the bath.

Place the overflow fascia over the overflow housing, make sure the slots for the outlet and overflow are on the underside. Tighten by screwing the grubscrew located on the underside of the overflow fascia.

Connect to the supply pipe work.

Installation - Pop-up waste

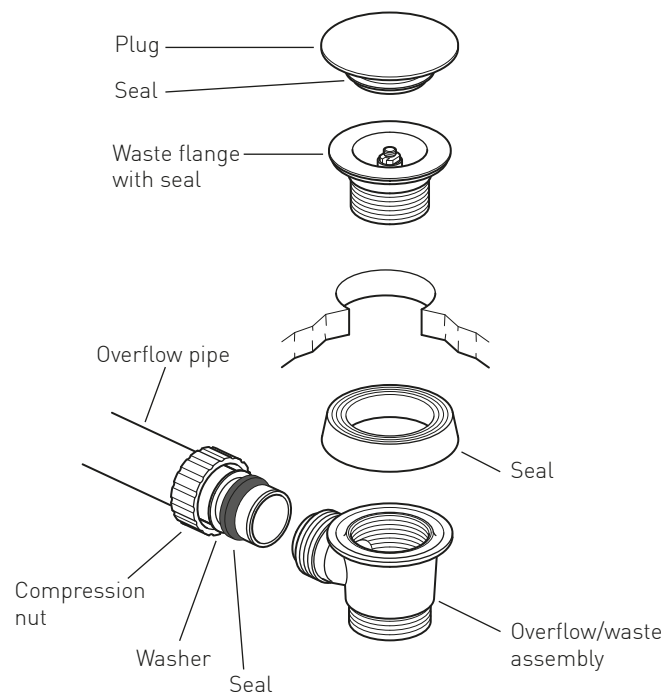

Push the seal onto the waste assembly

From below push the assembly up under the hole in the bath, and hold in place.

From inside the bath screw the waste flange into the assembly and tighten by hand, (do not over tighten as this may damage the parts and/or the bath).

Slide the compression nut, washer and seal over the pipe, push the pipe fully into the waste assembly, slide along the seal and washer and finally screw on the nut, hand tight only.

Screw on the plug.

Decreasing the pipe length.

The pipe can be shortened by carefully cutting, removing any burrs.

Ensure all calculations are correct before cutting the pipe.

Finish by following the above procedure

Operation

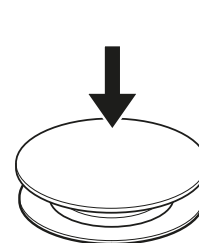

Push down to open the plug.

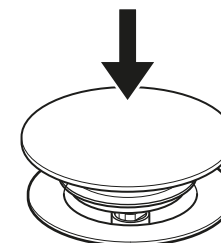

Push down again to close the plug.

Cleaning instructions

The physical vapor deposition coating on this product is finished to the highest standard. Due care needs to be taken to ensure the appearance is retained. We recommend cleaning all products with a soft damp cloth ONLY and advise strongly against the use of all aggressive/corrosive cleaning products i.e. powders and liquids. If these instructions are not followed, this may invalidate your guarantee in the event of a problem occurring.

Guarantee

All VADO products come with a 2 year guarantee as standard. Within this guarantee period VADO will provide replacement parts and any labour **[SEE NOTE 1]** needed to complete the product repair.

This standard guarantee may be extended by registering your product to give the following guarantee periods, once registered:

Brassware products from the Individual by VADO collection have a 15 year guarantee (2 years parts and labour plus 13 years parts only).

VADO Sensori SmartTouch and SmartDial products have a 5 year guarantee (parts and labour).

VADO Identity and i-tech products have a 5 year guarantee (2 year parts and labour plus 3 years parts only).

All other VADO products have a 3 year guarantee (2 years parts and labour plus 1 year parts only)

[SEE NOTE 2].

Guarantee Conditions

Our products are guaranteed against manufacturing defects from the date of purchase until the expiry of the relevant guarantee period shown above.

The guarantee is only valid if:

- The product has been installed, used and maintained in accordance with VADO's instructions and subjected to normal use only.
- The defect is not due to use of an unsuitable or inadequate water or power supply.
- The defect is not due to accident, misuse, neglect or incorrect/inappropriate repair (other than by VADO or VADO authorised agents) or damage caused by foreign objects or substances.
- The extended guarantee is only available if you have completed the Guarantee Registration Process.

This can be done via the VADO website or via phone to our aftersales team.

Registration must be completed within 6 months from date of purchase.

Under the extended guarantee period VADO will, at its option, offer to supply any replacement product (or component part) assessed to be defective **[SEE NOTE 3].**

The guarantee (whether standard or extended) is non-transferable to any subsequent owner.

All claims under the guarantee should be notified in the first instance to our Aftersales department, contact details below, this must be done no later than the last day of the relevant guarantee period.

All claims must be accompanied by proof of purchase (sales receipt or delivery note) from an official VADO dealer.

The guarantee does not extend to any consequential loss or damage.

After repair or replacement, the relevant guarantee period will be calculated from the original date of purchase.

VADO operates a policy of continuous product development and therefore reserves the right to change the product, packaging and documentation specifications without notice. E&OE.

NOTES:

[1] Labour via our engineer network is only available in the UK. Attendance by a VADO engineer or sub-contract engineer will be under our standard terms and conditions.

[2] VADO spare parts and shower hoses are under a parts only guarantee.

[3] VADO reserves the right to charge in advance for a product (or replacement part) pending collection and investigation (at VADO expense) to confirm a defect is due to a manufacturing issue.

If a defect is found the charge will be refunded or cancelled.

This guarantee is in addition to and does not affect your statutory rights as a consumer.

Tel: 01934 745163

Email: aftersales@vado.com