

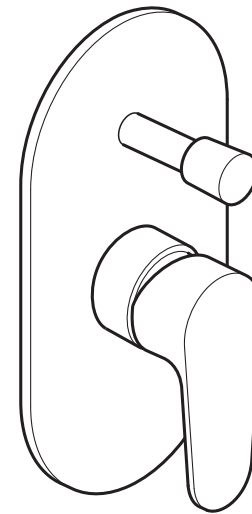

This instruction booklet covers model:
AX-AVA-147A-CP

AVA



INSTALLATION /
USER MANUAL

Important - please read

Please read these instructions carefully before starting installation and keep for future reference.

Remove all packaging and check the product for missing parts or damage before starting installation.

Any alterations made to this product and fittings may infringe water regulations and will invalidate the guarantee.

The installation must comply with all Local/National Water Supply Authority Regulations/Byelaws and Building and Plumbing Regulations.

To be installed in accordance with BS EN806.

We strongly recommend that you use a qualified and registered plumber.

General installation

This fitting is a mixing device and therefore water supplies should be reasonably balanced.

When installed, the fitting must comply with the requirements of the Water Supply (Water Fittings) Regulations 1999 and Scottish Byelaws 2004.

For further information, contact the Water Regulations department of your local water supplier (see the WRAS website www.wras.co.uk for details) or the Water Regulations Advisory Scheme by email (info@wras.co.uk) or telephone: 01495848454.

Before making any inlet pipe connections, all supply pipes MUST be thoroughly flushed to remove debris. Failure to do so could result in damage or low flow from the mixer unit. Water Supply (Water Fittings) Regulations 1999 Schedule 2 Section 13.

The fitting of isolating valves to the inlet feeds is advised for ease of maintenance.

Please take great care when installing this mixer not to damage its surface.

Please note if installing in an enclosed environment, access should be left for servicing and maintenance. No costs relating to inadequate access can be accepted.

Operating Specifications

Operating Pressure

Minimum operating pressure for shower **0.2 bar**

Minimum operating pressure for bath **1.5 bar**

Maximum operating pressure **5 bar**

Contents of Packaging

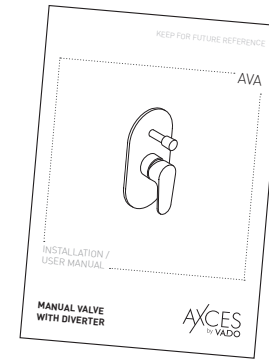

Installation guide &
User manual

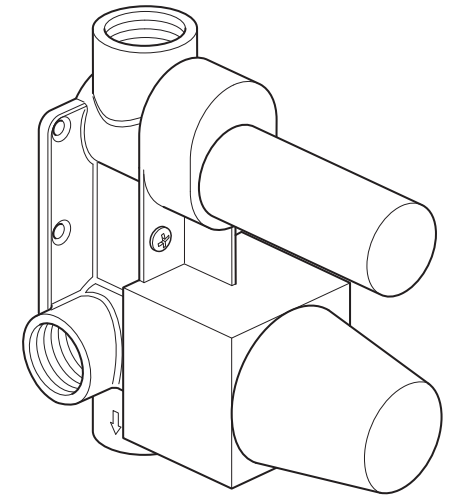

Valve with mortar guard

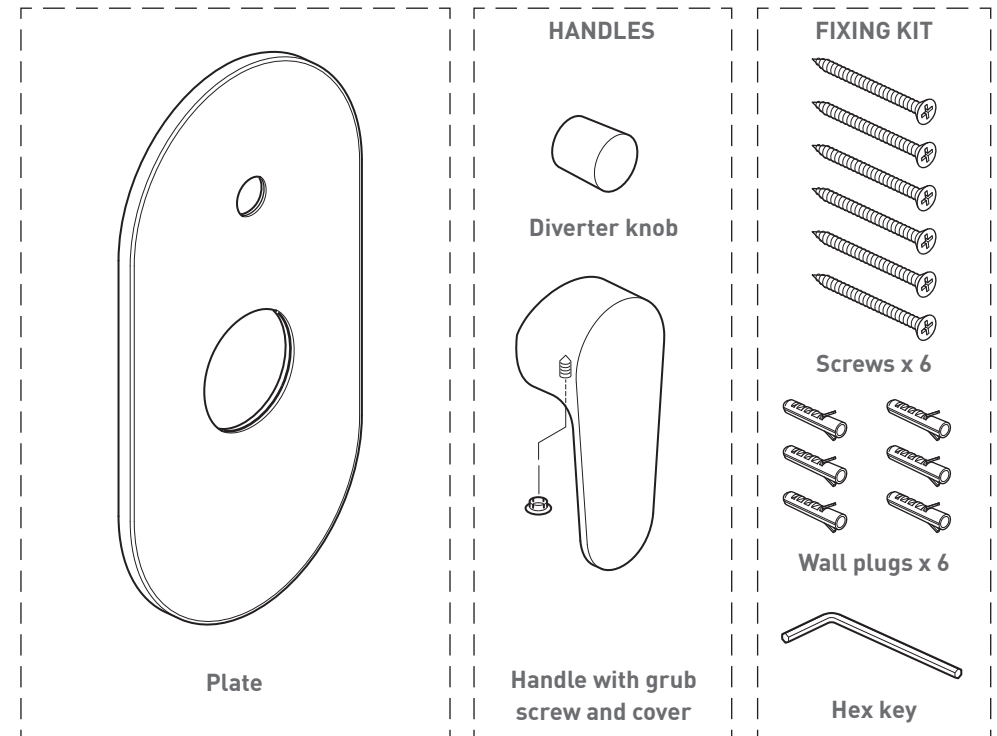

Plate

Handle with grub
screw and cover

Hex key

Dimensions

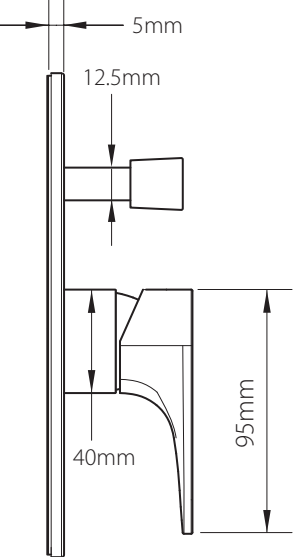
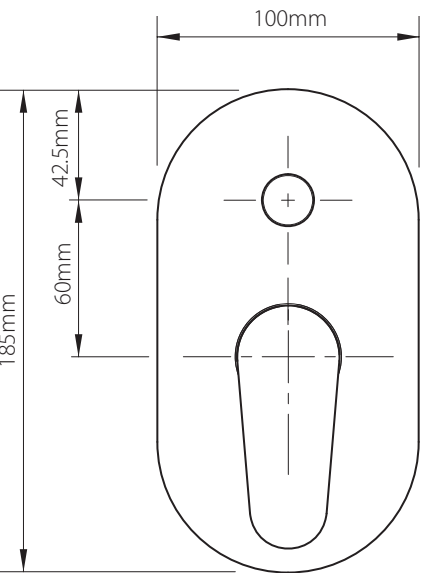
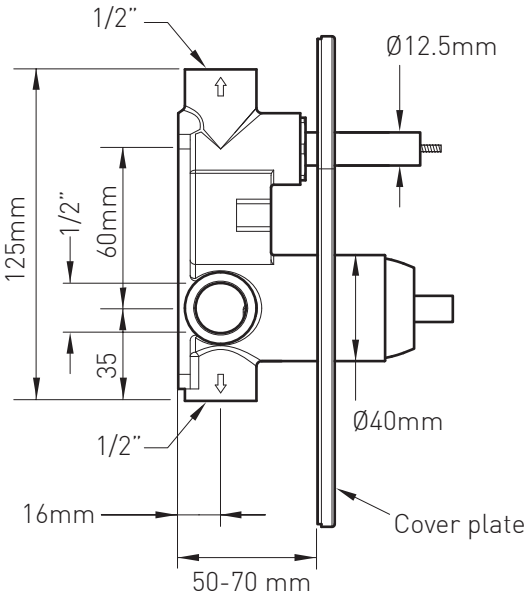

Installation - Quick guide

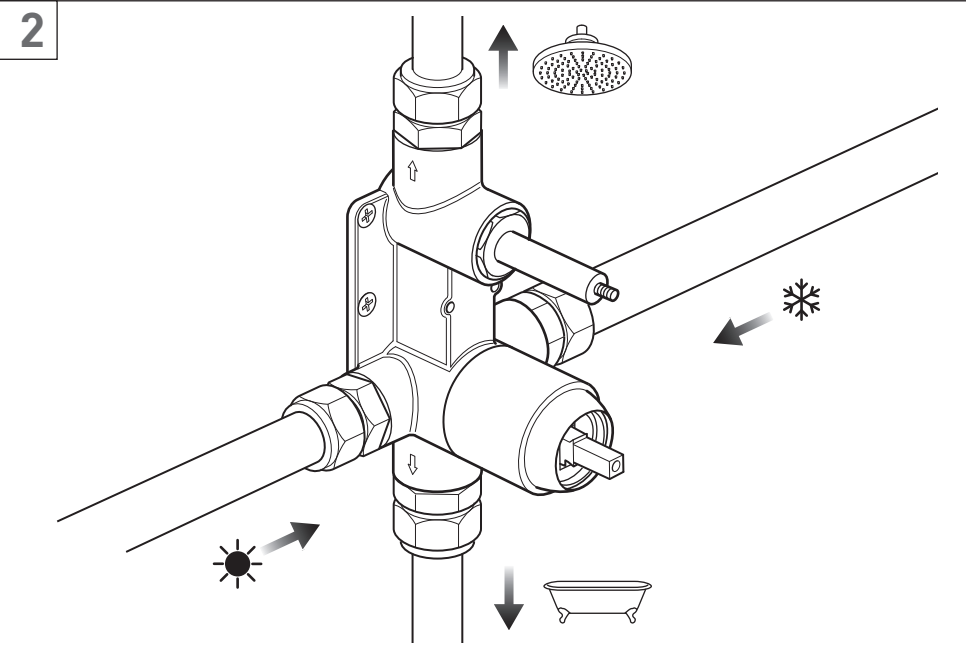
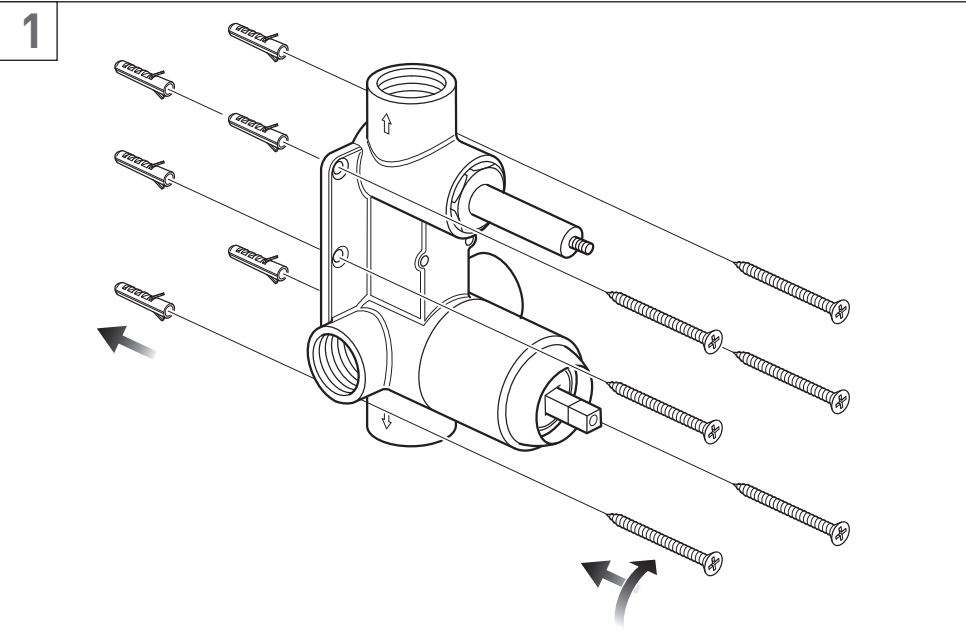

Installation - Quick guide

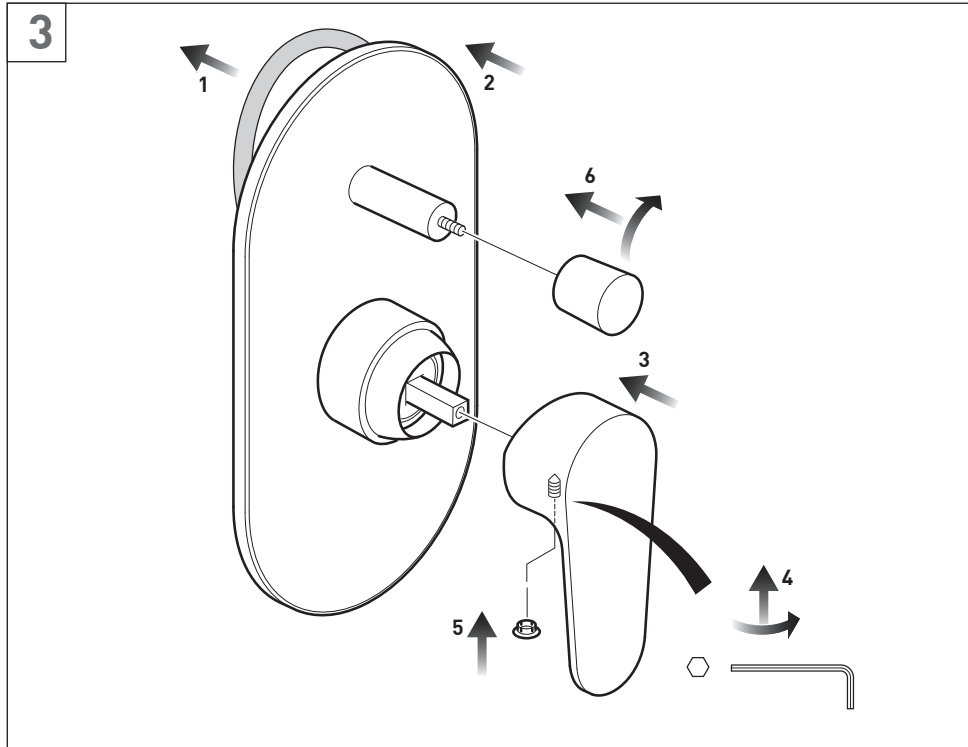

Installation

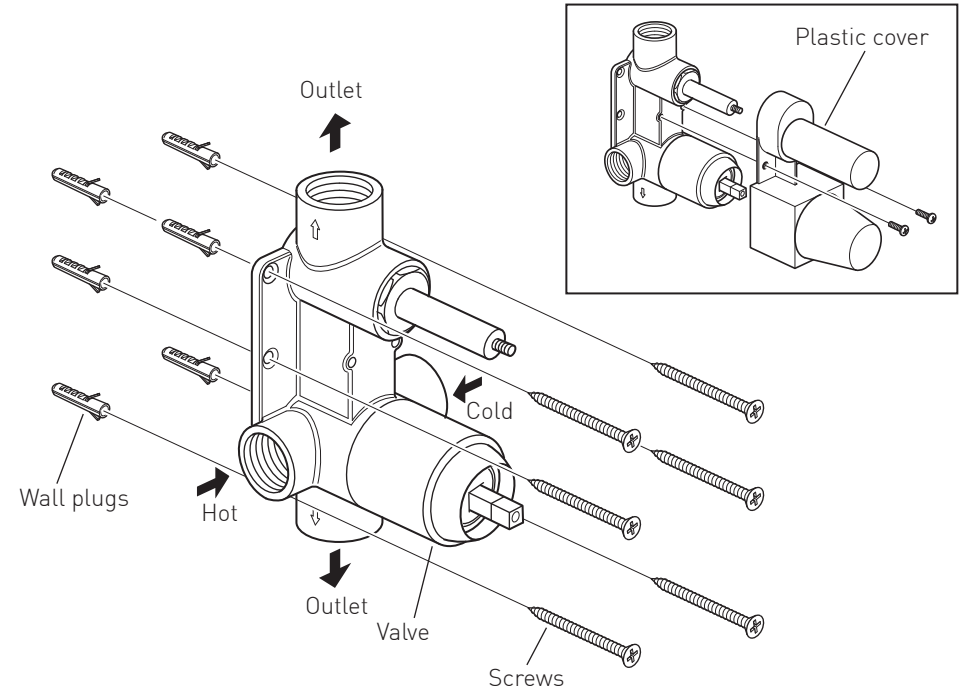

Before installing your new mixer, flush through the pipework to ensure removal of debris, turn off the water supply.

⚠ Warning! Please check for any hidden cables and pipes before drilling holes in the wall.

Use the plastic cover as a depth guide and also as protection for the chrome surface during installation (see above).

The valve must be set into the wall by 50-70mm (see dimension page). If you are fitting the valve to a partition wall or a wall of particularly soft substrate you will need specialist fixings.

Select the position for the shower valve and offer the shower valve to the wall, mark the 6 fixing points at the top and bottom with a suitable pencil. Secure the valve to the wall with suitable fixings.

Make all connections to the valve. Connect hot supply to left inlet of the valve and cold supply to right inlet. Connect the outlets to the desired channels e.g. top outlet to the showerhead and bottom outlet to the bath.

Finish the wall, keep the final finished wall surface between the min and max dimensions.

Installation

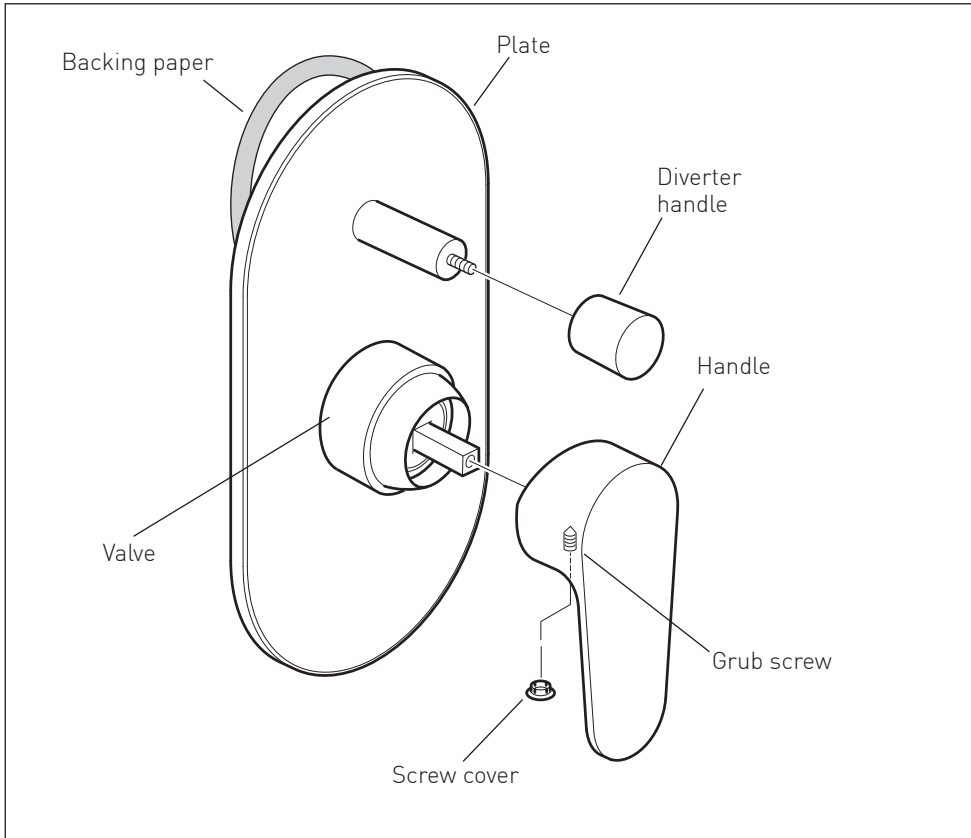

Remove the backing paper from the seal located on the back of the plate. Slide the plate over the valve, push onto the wall until it makes contact.

Carefully slide the control handle onto the valve and secure in position with the grub screw located within the handle using the hexagonal key supplied, replace the screw cover.

Screw on the diverter handle.

Note: If the valve is sited within a wet environment, it is recommended that once the valve is commissioned the plate is sealed with a thin bead of sealant around three sides to provide a water-tight seal between the plate and the wall material, leaving the bottom edge free to allow for maintenance purposes.

Operation

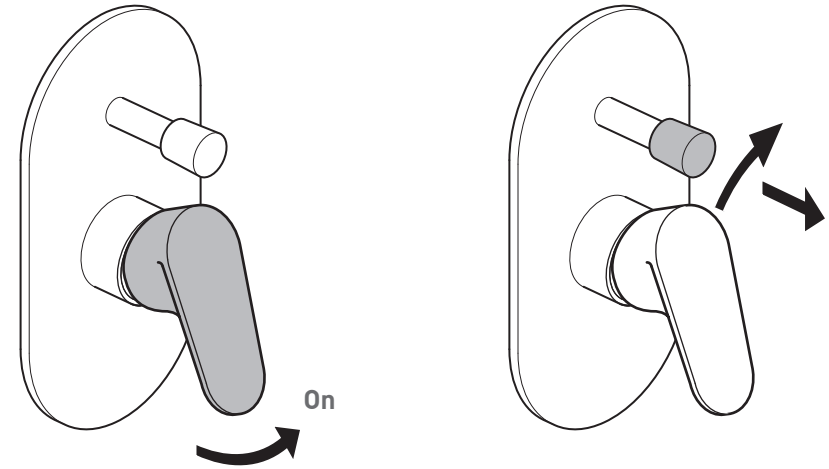

Pulling the mixer lever outwards will increase the flow of water.

Pull the diverter handle and turn clockwise to lock into position. Turn clockwise again to release the diverter and go back to the primary outlet.

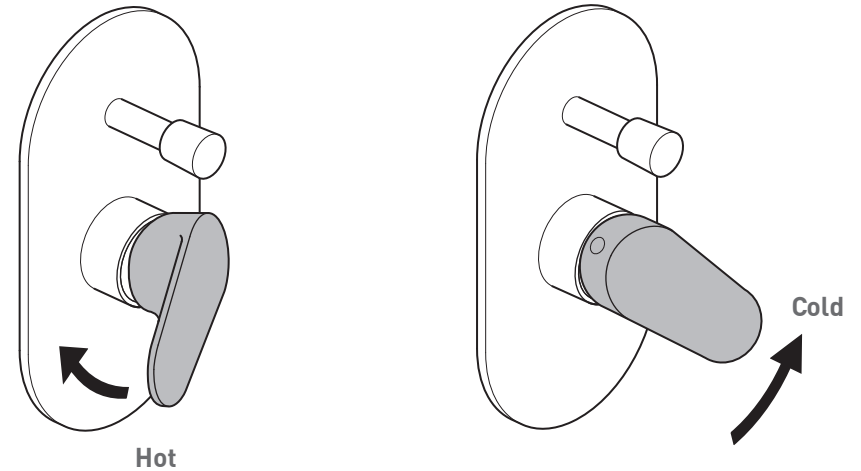

Moving the mixer lever from right to left will increase the water temperature.

Moving the mixer lever from left to right will decrease the water temperature.

Cleaning instructions:

Our products are finished to the highest standard and due care needs to be taken to ensure their looks are retained.

We recommend cleaning all products with a soft damp cloth ONLY and advise strongly against the use of ALL cleaning products i.e. powders and liquids.

If the above instructions are not followed this will invalidate your guarantee in the event of a problem occurring.

Guarantee

All AXCES by VADO products come with a 2 year guarantee as standard. Within this guarantee period VADO will provide replacement parts and any labour **[SEE NOTE 1, GUARANTEE CONDITIONS]** needed to complete the product repair.

This standard guarantee may be extended by registering your product to give a 10 year guarantee (2 years parts and labour plus 8 years on parts supply only.).

Operational components such as, but not limited to; thermostatic cartridges, diverters, headworks and flow control, waste mechanisms, shower hoses, O-rings and seals are guaranteed for 2 years parts and labour plus 3 years on parts supply only.

Guarantee Conditions

Our products are guaranteed against manufacturing defects from the date of purchase until the expiry of the relevant guarantee period shown above.

The guarantee is only valid if:

- The product has been installed, used and maintained in accordance with VADO's instructions and subjected to normal use only.
- The defect is not due to use of an unsuitable or inadequate water or power supply.
- The defect is not due to accident, misuse, neglect or incorrect/inappropriate repair (other than by VADO or VADO authorised agents) or damage caused by foreign objects or substances.
- The extended guarantee is only available if you have completed the Guarantee Registration Process. This can be done via the VADO website or via phone to our aftersales team. Registration must be completed within 6 months from date of purchase.

Under the extended guarantee period VADO will, at its option, offer to supply any replacement product (or component part) assessed to be defective **[SEE NOTE 2]**.

The guarantee (whether standard or extended) is non-transferable to any subsequent owner.

All claims under the guarantee should be notified in the first instance to our Aftersales department, contact details below, this must be done no later than the last day of the relevant guarantee period. All claims must be accompanied by proof of purchase (sales receipt or delivery note) from an official AXCES by VADO dealer.

The guarantee does not extend to any consequential loss or damage.

After repair or replacement, the relevant guarantee period will be calculated from the original date of purchase.

VADO operates a policy of continuous product development and therefore reserves the right to change the product, packaging and documentation specifications without notice.

NOTES:

[1] Labour via our engineer network is only available in the UK. Attendance by a VADO engineer or sub-contract engineer will be under our standard terms and conditions.

[2] VADO reserves the right to charge in advance for a product (or replacement part) pending collection and investigation (at VADO expense) to confirm a defect is due to a manufacturing issue. If a defect is found the charge will be refunded or cancelled.

This guarantee is in addition to and does not affect your statutory rights as a consumer.

Tel: 01934 745163

Email: aftersales@vado.com