

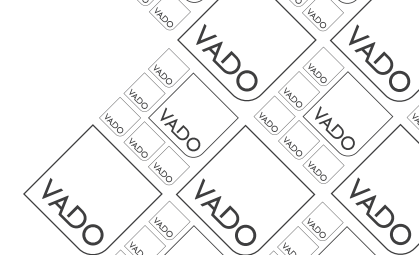

it's a personal experience

SKY



Installation Guide Ceiling Mounted Shower

This instruction booklet covers this model:
SKY-SQ35-CP, SKY-R038-CP

SKY-SQ35-CP
SKY-R038-CP

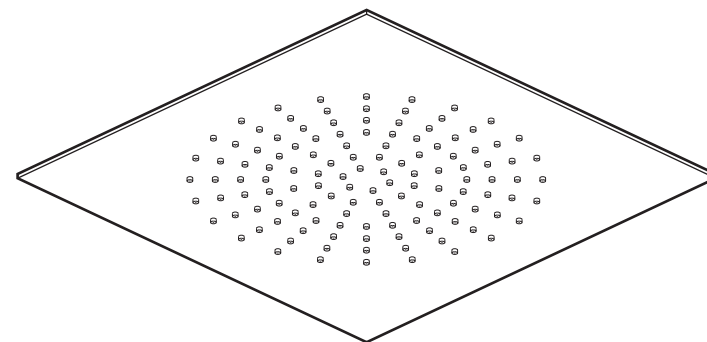

Vado
Wedmore Road, Cheddar, Somerset, England BS27 3EB
tel 01934 744466. fax 01934 744345
aftersales@vado.com
www.vado.com

Note: for illustrative purposes only the square model is shown.
Please follow the same procedure to install the round model.

Keep for future reference



Important - please read

Please read these instructions carefully before starting installation and keep for future reference.

Remove all packaging and check the product for missing parts or damage before starting installation.

Any alterations made to this product and fittings may infringe water regulations and will invalidate the guarantee.

The installation must comply with all Local/National Water Supply Authority Regulations/Byelaws and Building and Plumbing Regulations.

To be installed in accordance with BS EN806.

We strongly recommend that you use a qualified and registered plumber.

General installation

When installed, the fitting must comply with the requirements of the Water Supply (Water Fittings) Regulations 1999 and Scottish Byelaws 2004.

For further information, contact the Water Regulations department of your local water supplier (see the WRAS website www.wras.co.uk for details) or the Water Regulations Advisory Scheme by email (info@wras.co.uk) or telephone: 01495848454.

Before making any inlet pipe connections, all supply pipes MUST be thoroughly flushed to remove debris. Failure to do so could result in damage or low flow from the mixer unit.

The fitting of isolating valves to the inlet feeds is advised for ease of maintenance.

Please take great care when installing this mixer not to damage its surface.

Please note if installing in an enclosed environment, access should be left for servicing and maintenance. No costs relating to inadequate access can be accepted.

Operating Specifications

Operating Pressure

Minimum operating pressure 1 bar

Maximum operating pressure 5 bar

Cleaning instructions

The electroplating on this product is finished to the highest standard. Due care needs to be taken to ensure the appearance is retained.

We recommend cleaning all products with a soft damp cloth ONLY and advise strongly against the use of all aggressive/corrosive cleaning products i.e. powders and liquids. If these instructions are not followed, this may invalidate your guarantee in the event of a problem occurring.

To remove any build up of limestone on the shower head, just rub your fingers lightly over the nozzles.

Contents of Packaging

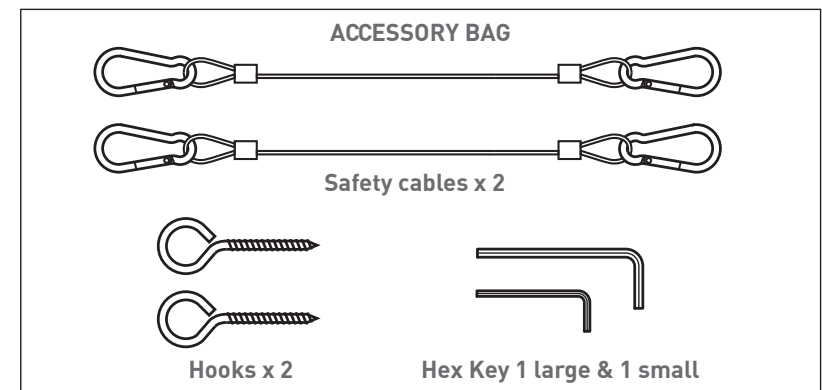
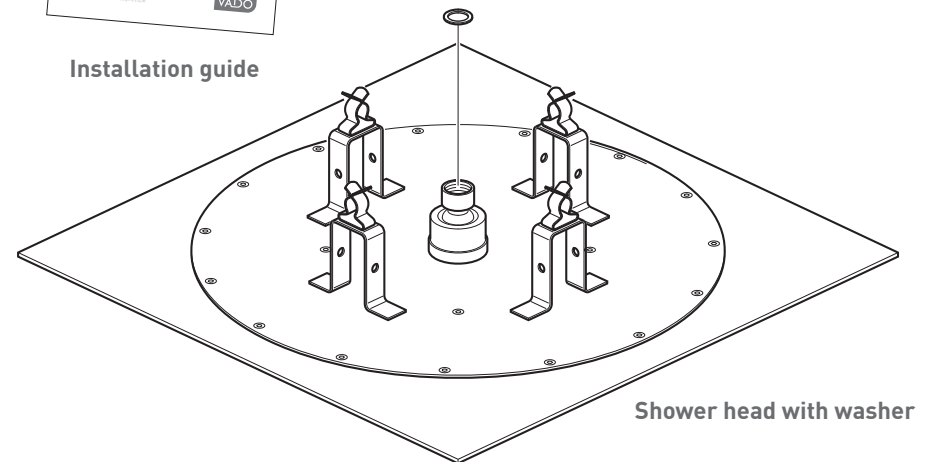
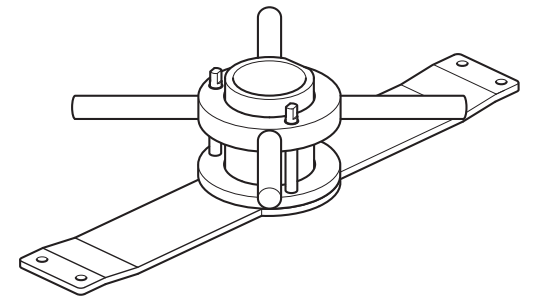
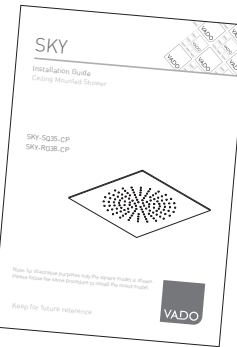
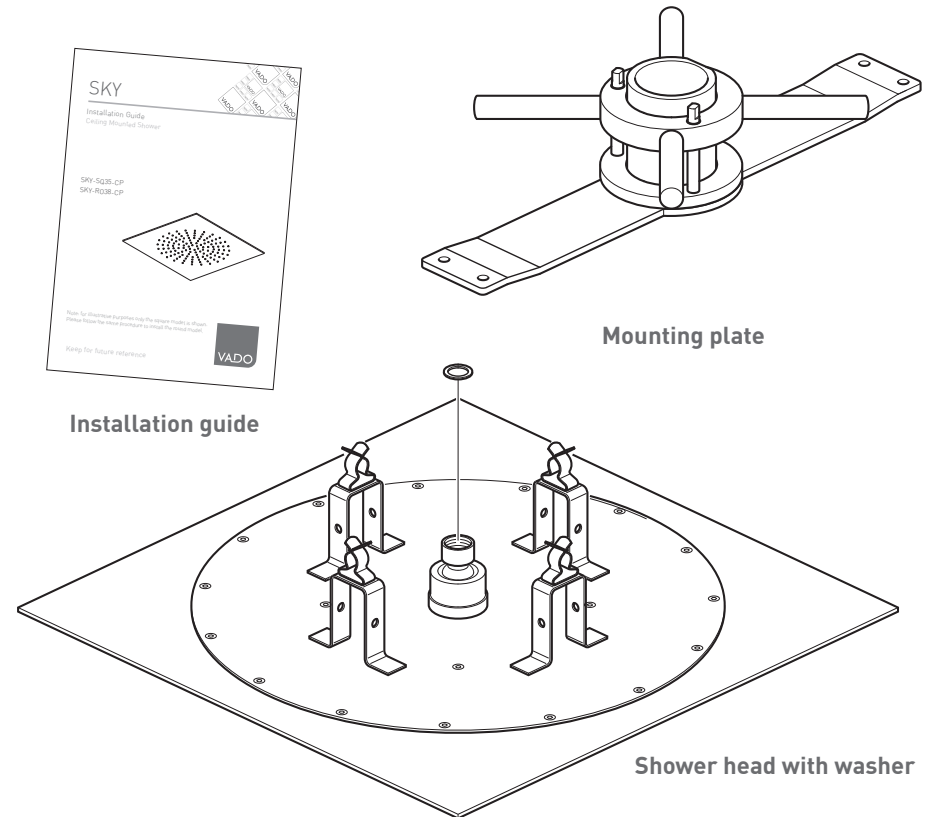

Dimensions - square

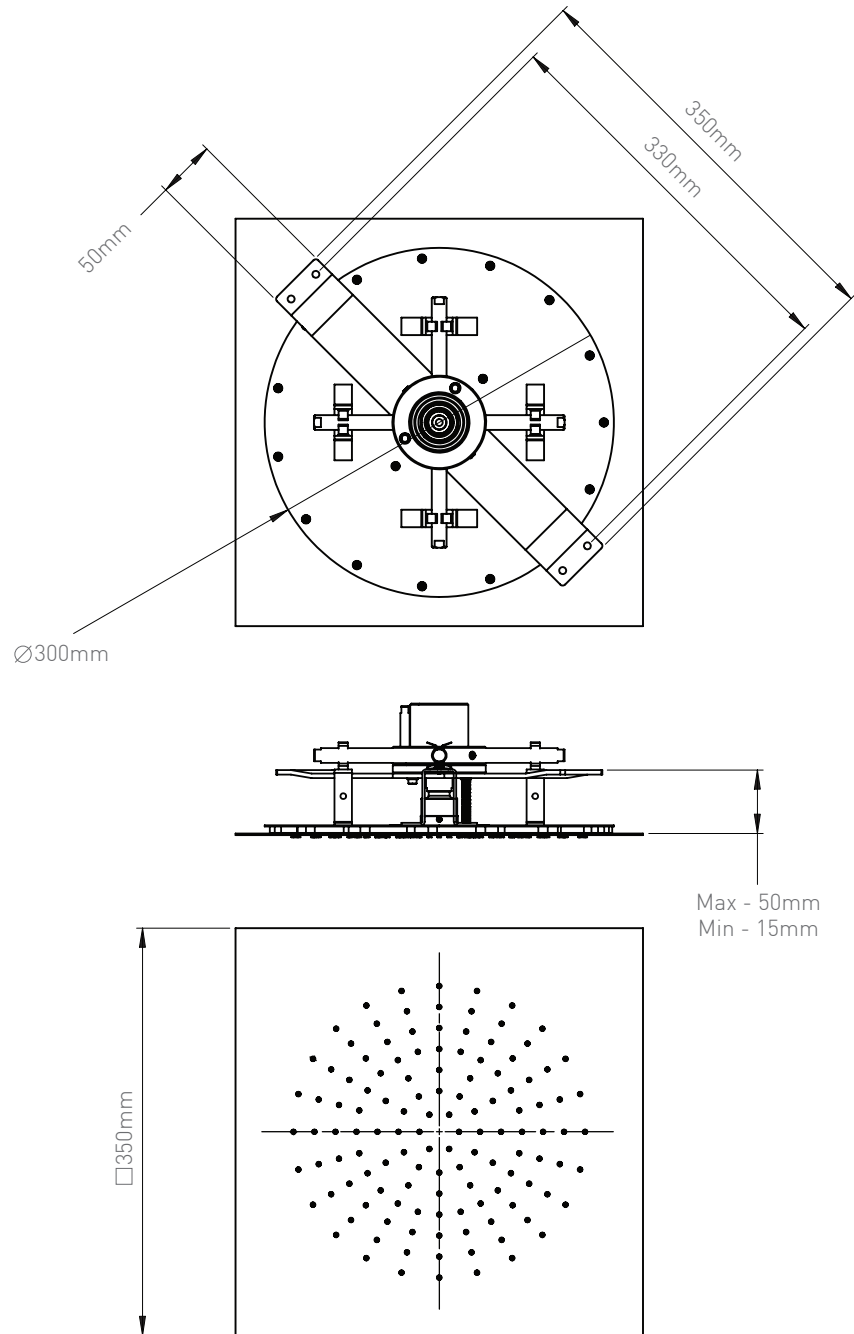

Dimensions - round

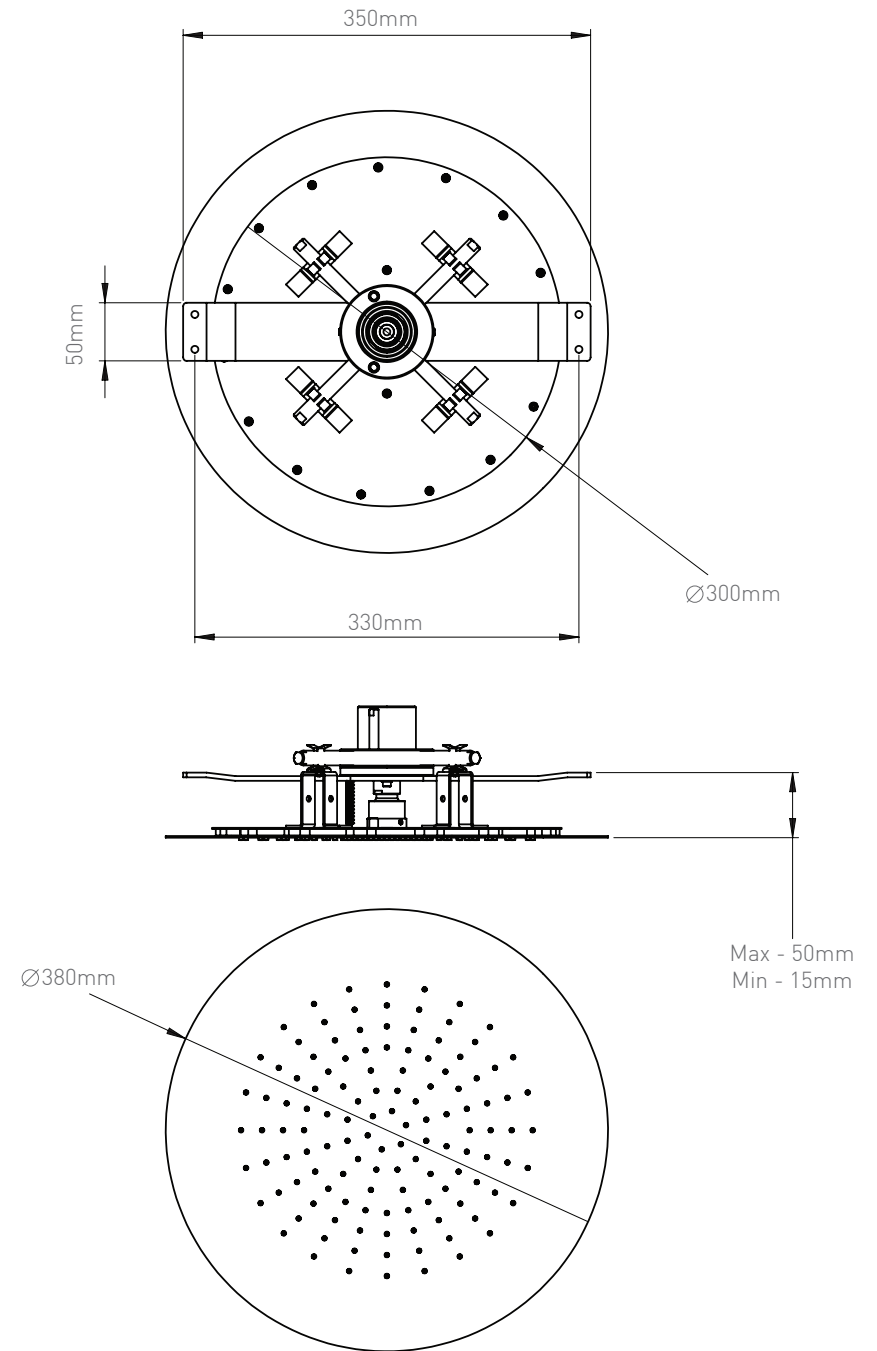

Installation

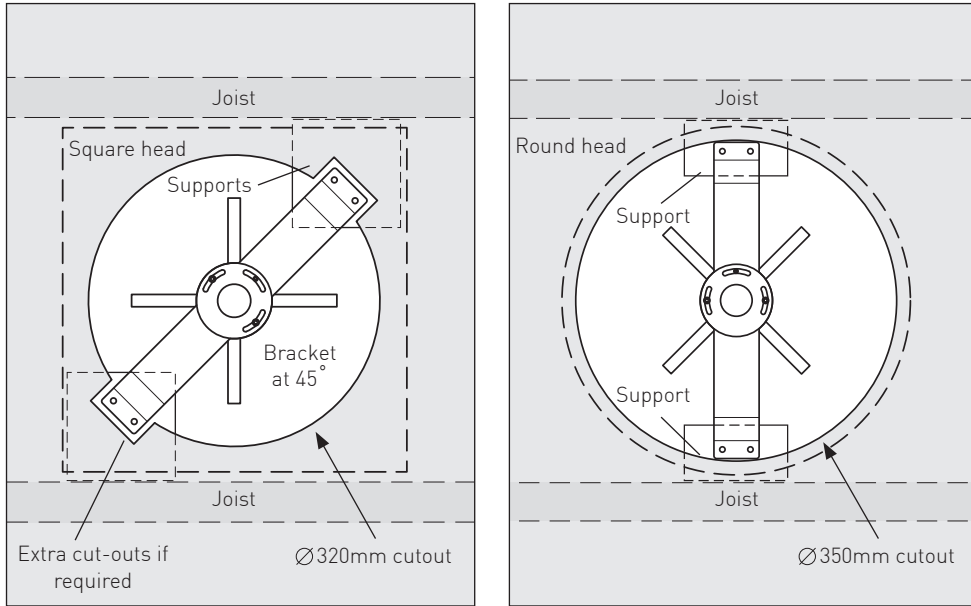

Please note:

Before installing flush through the pipe work to ensure removal of debris, turn off the water supply.

Warning!

Please check for any hidden cables and pipes before drilling any holes.

The bracket can be screwed directly into the ceiling joists or if this isn't possible, add supports where required. **IMPORTANT NOTE** - Ensure these are level with one another.

Square - In the required position cut a 320mm hole, two further rectangular cut-outs may need to be made if access to the bracket holes isn't available when securing in position. Ensure the bracket is set 45° to the wall that the head needs to be aligned with (see above).

Add additional noggins to support the mounting bracket if required.

Round - In the required position cut a 350mm hole, the mounting bracket can be secured to additional noggins in any orientation.

Installation

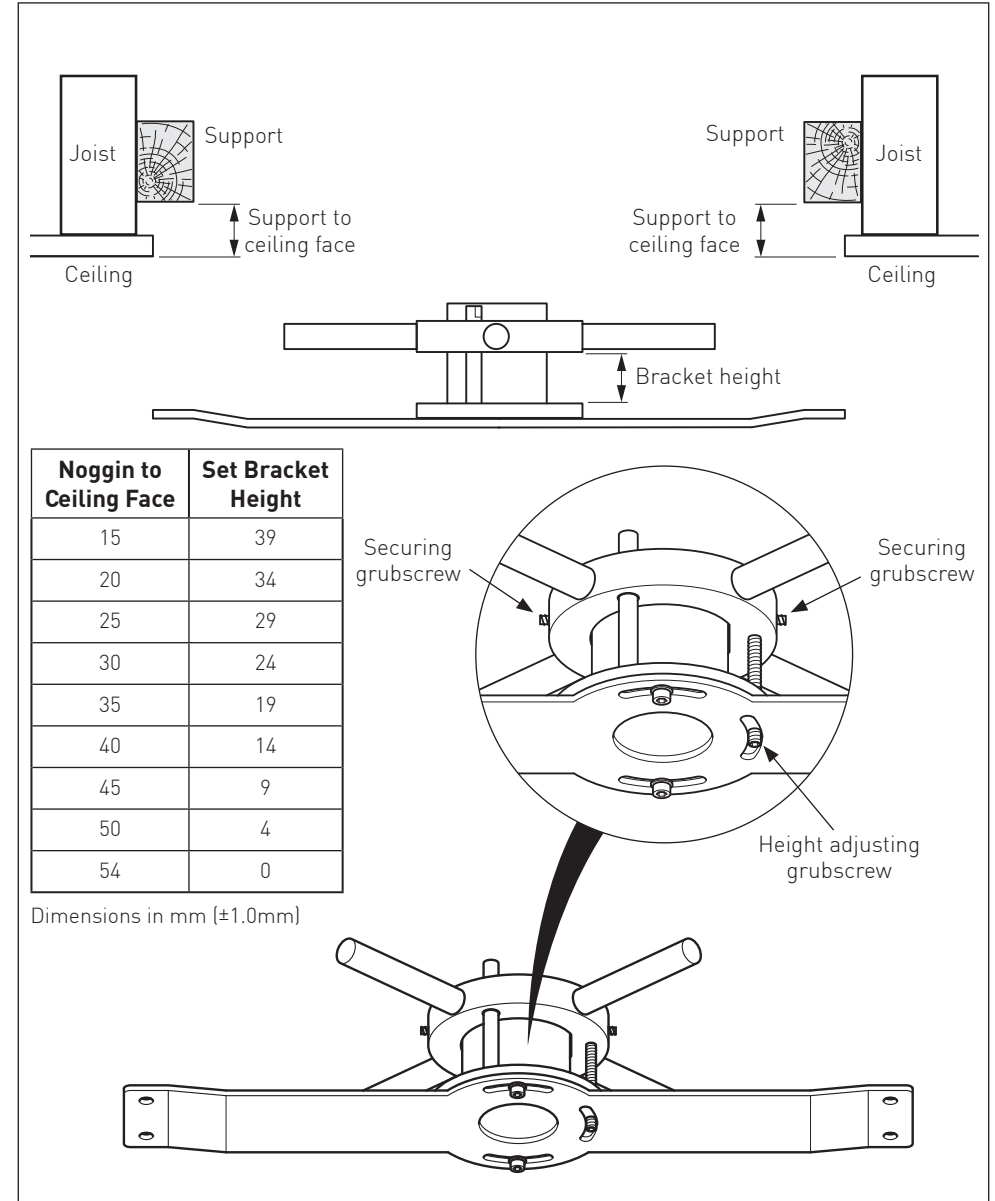

Measure the distance between the bottom surface of the support and the face of the ceiling, then use the reference table to determine what height to preset the bracket at. Adjust the height using the grub screw, then secure into position with the top 2 grub screws.

Installation

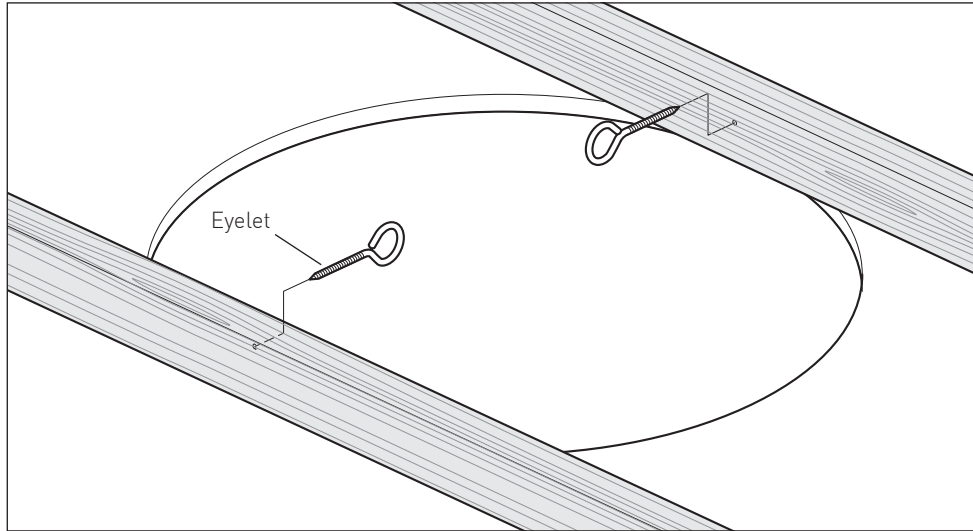

Securely screw the two eyelets into the ceiling joists/support.

Installation

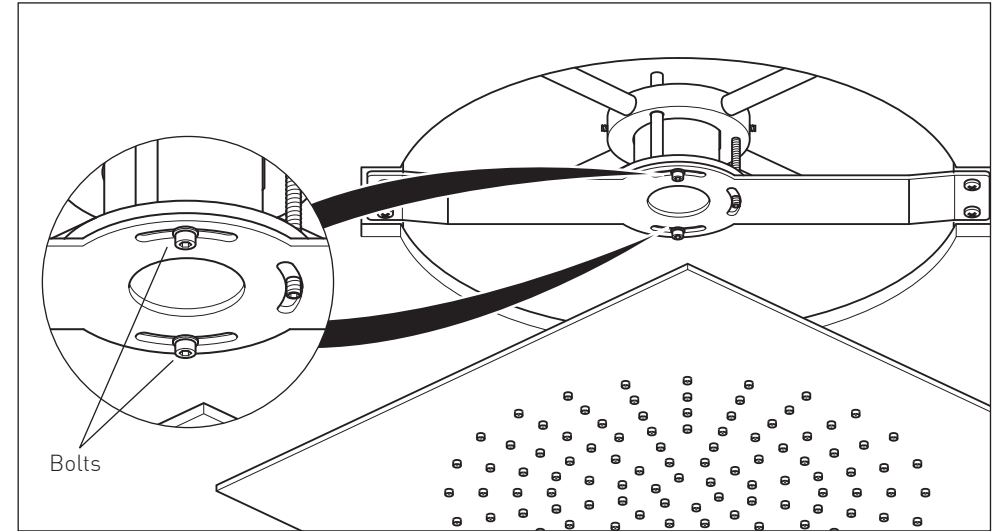

If fitting the square shower head and alignment is required with the edge of the room etc, there is the option for fine rotational adjustment once the bracket has been installed. Undo the 2 bolts underneath the bracket and rotate the arms to the desired location, then secure the bolts again.

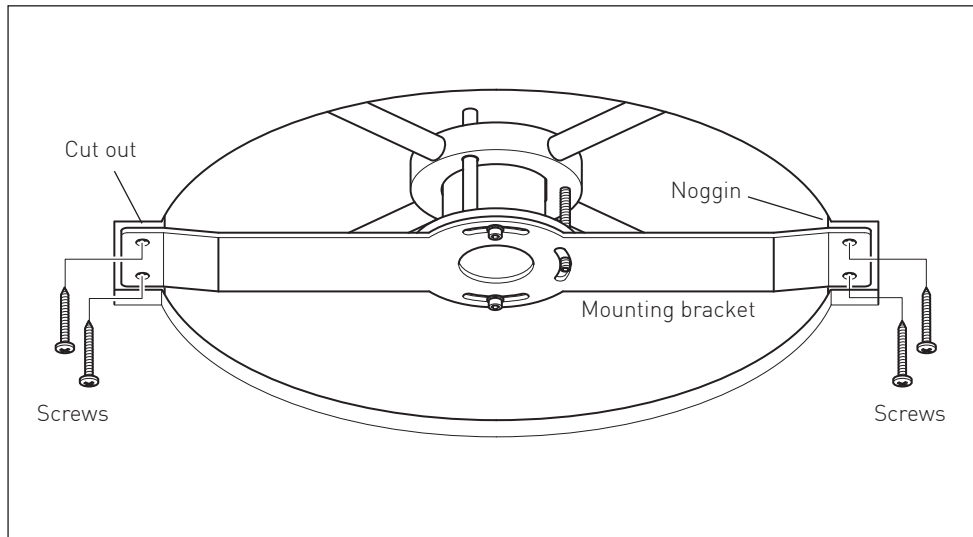

Position the mounting bracket and secure in place with 4 suitable screws, ensuring it is level.

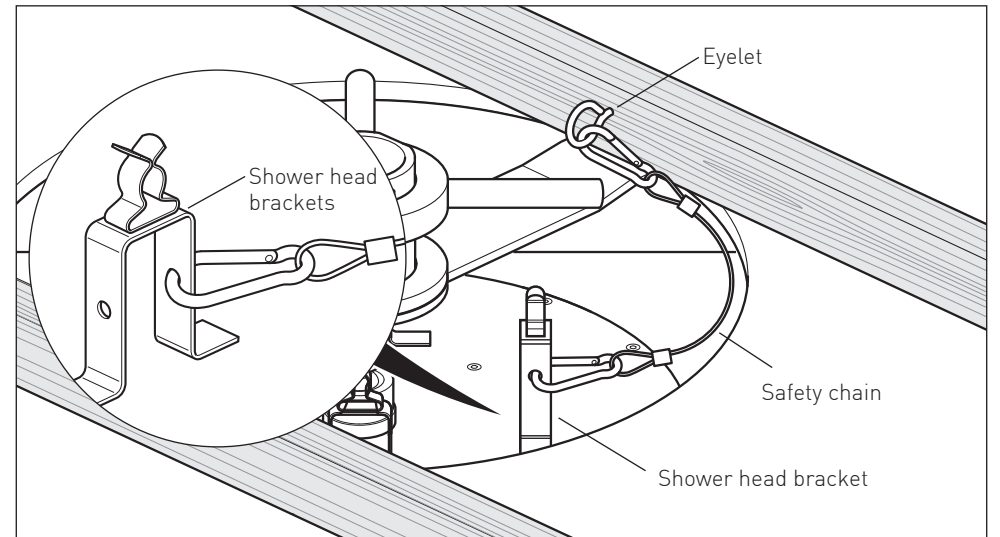

Attach the two easy clip safety chains. Clip one end of the safety chain to the eyelet and the other end into one of the holes on the shower head bracket. Repeat for the other side.

Installation

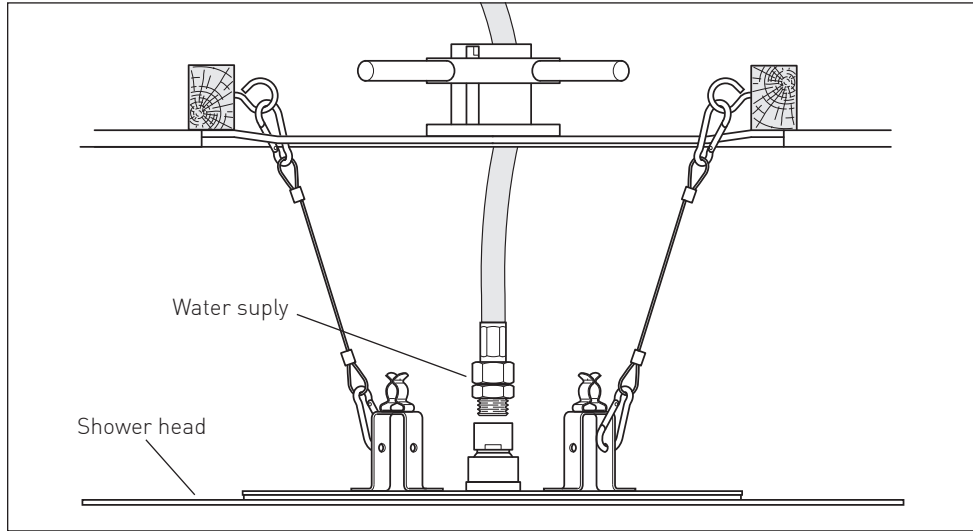

Using a flexible pipe connect the water supply to the shower head. Turn on flow and check for leaks.

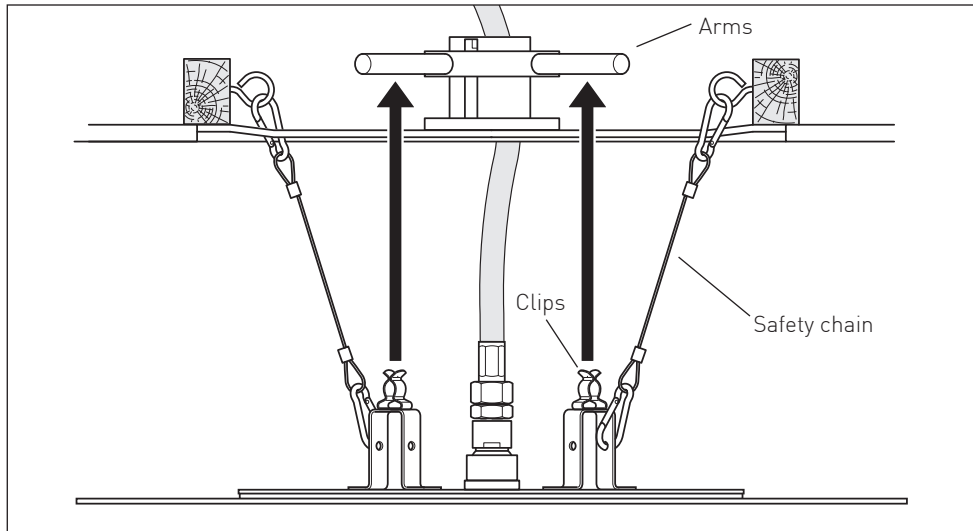

Align the clips directly below the arms, push the shower head until the clips snap into position.

If it is still not flush with the ceiling or not aligned squarely, take a reference measurement, then gently pull the edge of the head downwards to remove. Adjust the height or rotation appropriately, one full turn of the height adjusting grub screw is 1mm of vertical movement.

Installation - Quick guide

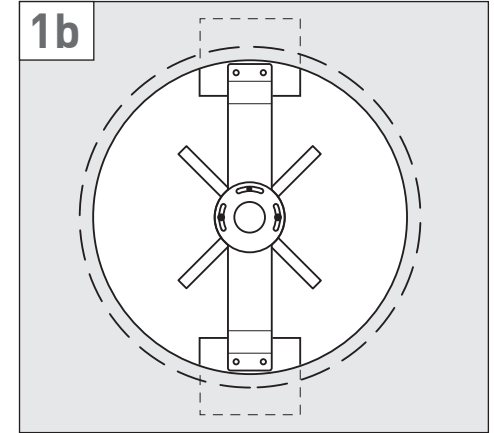
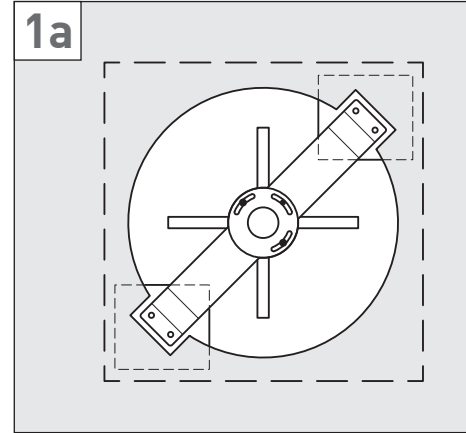

2

A	B
15	39
20	34
25	29
30	24
35	19
40	14
45	9
50	4
54	0

±1.0mm

Installation - Quick guide

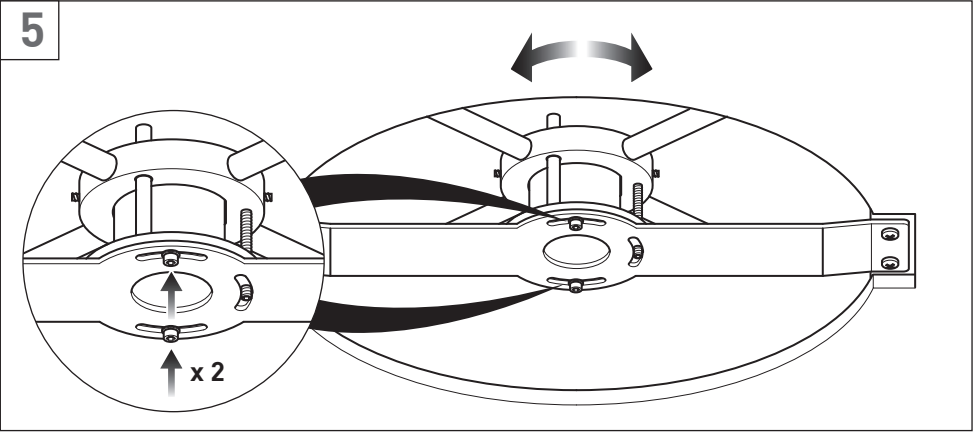
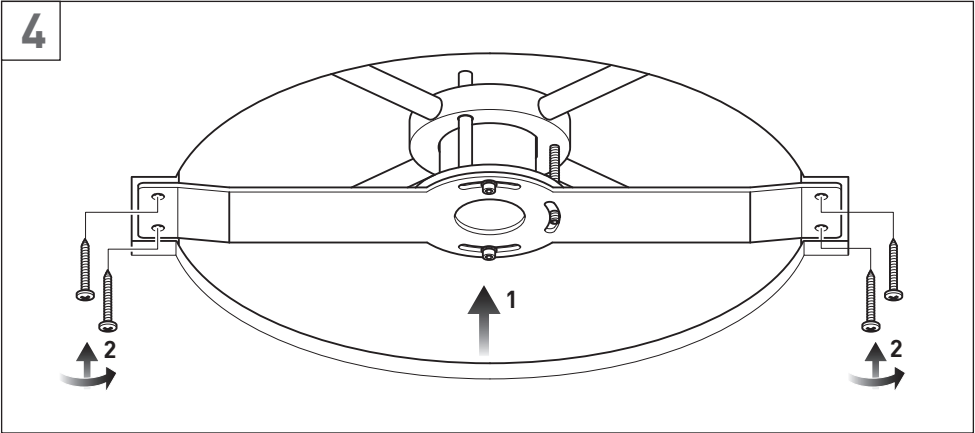
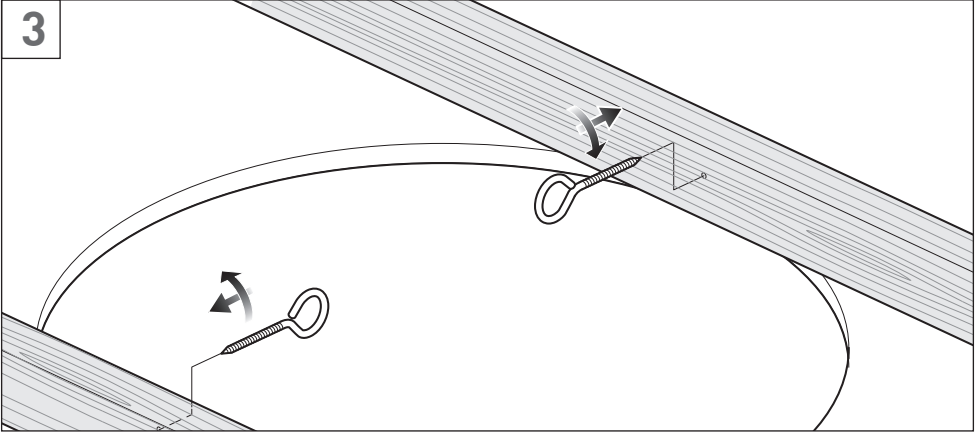

Installation - Quick guide

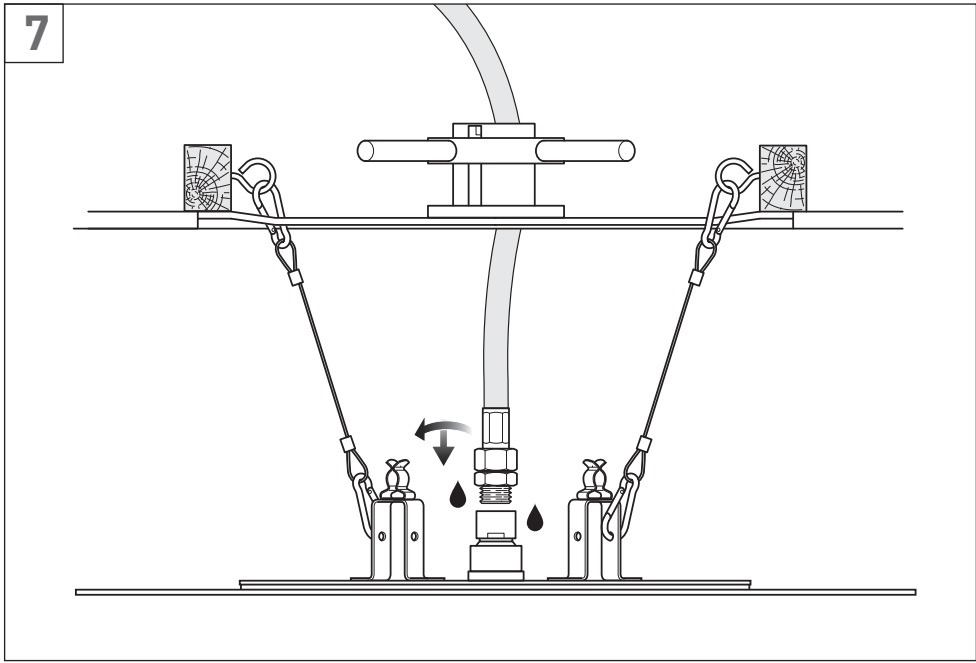
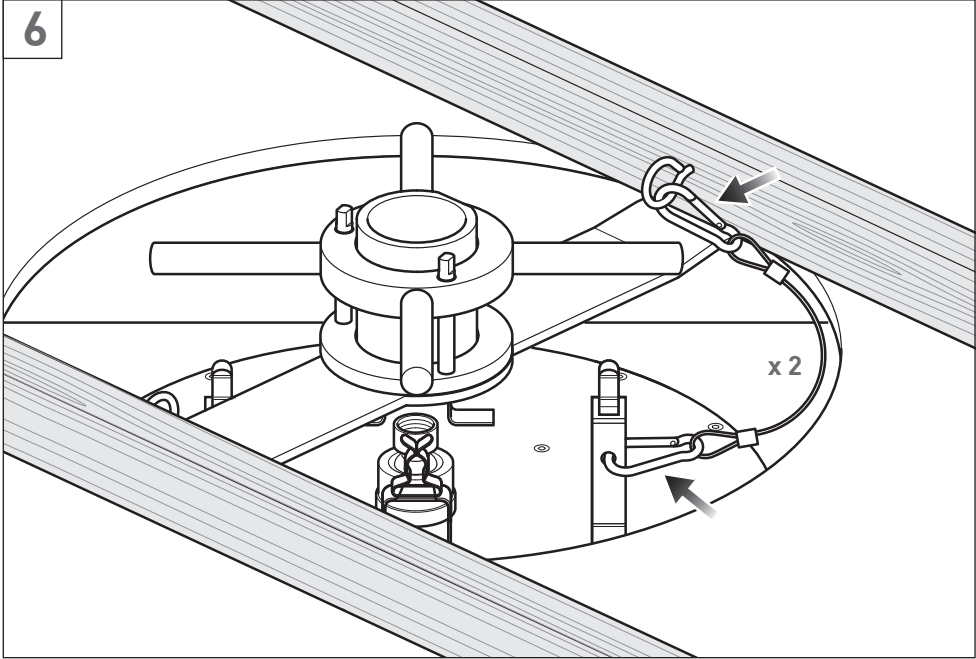

Installation - Quick guide

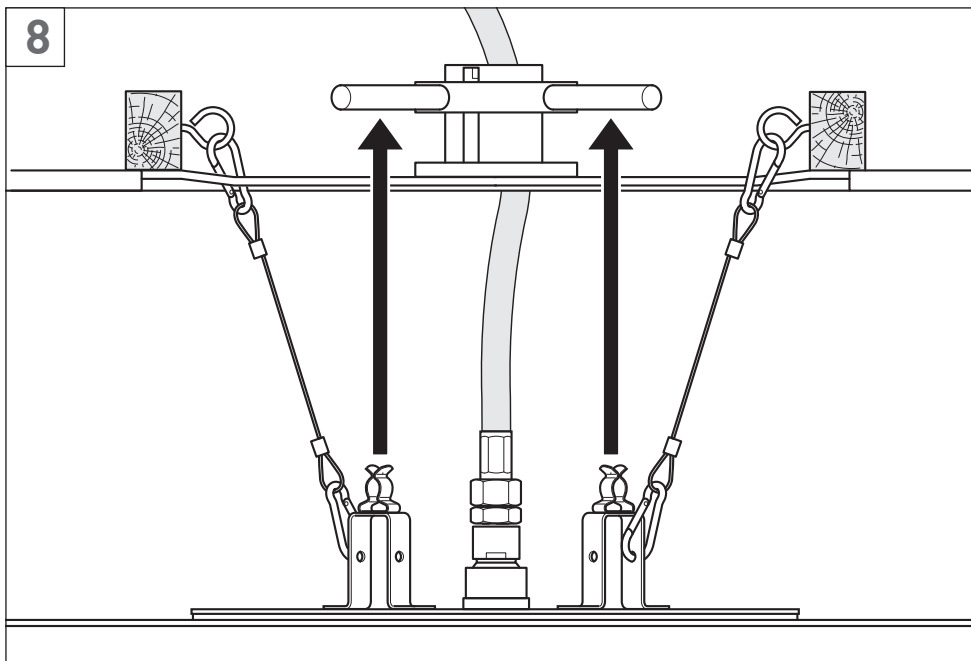

Guarantee

All VADO products come with a 2 year guarantee as standard. Within this guarantee period VADO will provide replacement parts and any labour **[SEE NOTE 1]** needed to complete the product repair.

This standard guarantee may be extended by registering your product to give up to a 12 year guarantee period. Once registered:

VADO chromed brassware and stainless steel products have a 12 year guarantee (2 years parts and labour plus 10 years parts only).

VADO Sensori Smart Touch and Smart Dial products have a 5 year guarantee (parts and labour).

VADO Identity and i-tech products have a 5 year guarantee (2 year parts and labour plus 3 years parts only).

All other VADO products have a 3 year guarantee (2 years parts and labour plus 1 year parts only)

[SEE NOTE 2].

VADO electric showers have a 2 years parts and labour guarantee.

Guarantee conditions

Our products are guaranteed against manufacturing defects from the date of purchase until the expiry of the relevant guarantee period shown above.

The guarantee is only valid if:

- The product has been installed, used and maintained in accordance with VADO's instructions and subjected to normal use only.
- The defect is not due to use of an unsuitable or inadequate water or power supply.
- The defect is not due to accident, misuse, neglect or incorrect/inappropriate repair (other than by VADO or VADO authorised agents) or damage caused by foreign objects or substances.
- The extended guarantee is only available if you have completed the Guarantee Registration Process.

This can be done via the VADO website or via phone to our aftersales team. Registration must be completed within 6 months from date of purchase.

Under the extended guarantee period VADO will, at its option, offer to supply any replacement product (or component part) assessed to be defective **[SEE NOTE 3].**

The guarantee (whether standard or extended) is non-transferable to any subsequent owner. All claims under the guarantee should be notified in the first instance to our Aftersales department, contact details below, this must be done no later than the last day of the relevant guarantee period. All claims must be accompanied by proof of purchase (sales receipt or delivery note) from an official VADO dealer.

The guarantee does not extend to any consequential loss or damage.

After repair or replacement, the relevant guarantee period will be calculated from the original date of purchase.

VADO operates a policy of continuous product development and therefore reserves the right to change the product, packaging and documentation specifications without notice.

NOTES:

[1] Labour via our engineer network is only available in the UK. Attendance by a VADO engineer or sub-contract engineer will be under our standard terms and conditions.

[2] VADO spare parts and shower hoses are under a parts only guarantee.

[3] VADO reserves the right to charge in advance for a product (or replacement part) pending collection and investigation (at VADO expense) to confirm a defect is due to a manufacturing issue. If a defect is found the charge will be refunded or cancelled. This guarantee is in addition to and does not affect your statutory rights as a consumer.

Tel: 01934 745163

Email: aftersalescare@vado.com