



where inspiration flows

CAMEO

Installation Guide
Wall Hung WC Pans, Round and Soft Square

This instruction booklet covers these models:

CAM-WC-WH-RO, CAM-WC-WH-SQ

CAM-WC-WH-RO
CAM-WC-WH-SQ

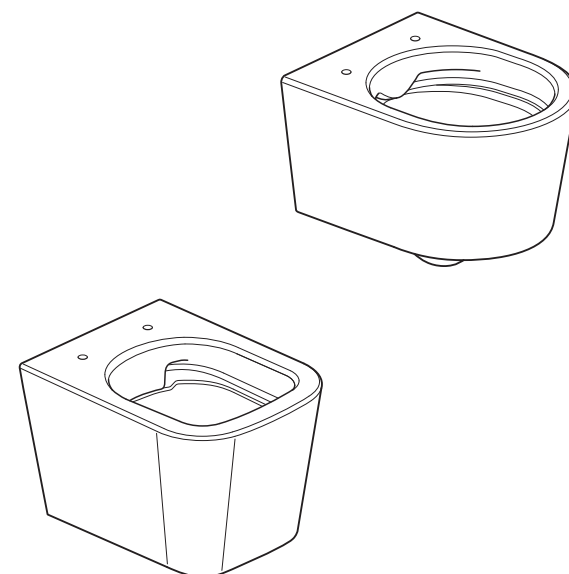

Vado
Wedmore Road, Cheddar, Somerset, England BS27 3EB
tel 01934 744466 fax 01934 744345
aftersales@vado.com
www.vado.com



Important - please read

VADO reserves the right to make technical improvements and enhance the appearance of the products included in this instruction manual.

Please read these instructions carefully before starting the installation and keep for future reference.

Remove all packaging and check the product for missing parts or damage before starting installation.

Any alterations made to this product and fittings may infringe water regulations and will invalidate the guarantee.

The installation must comply with the requirements of the Water Supply (Water Fittings) Regulations 1999 and Scottish Byelaws 2004.

For further information, contact the Water Regulations department of your local water supplier (see the WRAS website www.wras.co.uk for details) or the Water Regulations Advisory Scheme by email (info@wras.co.uk) or telephone: 01495848454.

This product can be dangerous if installed incorrectly. This product must be installed by a qualified plumber or installer.

Please take great care when installing this product not to damage its surface.

Contents of Packaging

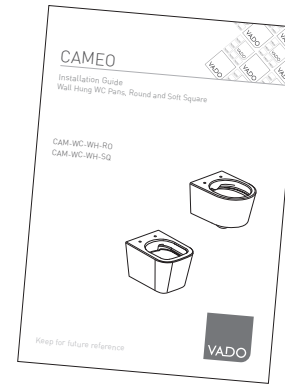

Installation guide

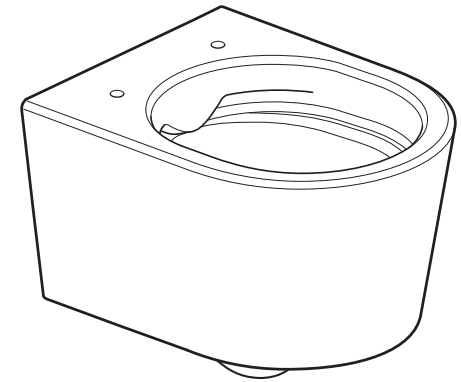

CAM-WC-WH-RO

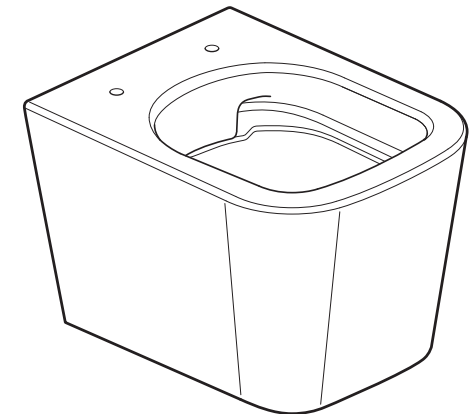

CAM-WC-WH-SQ

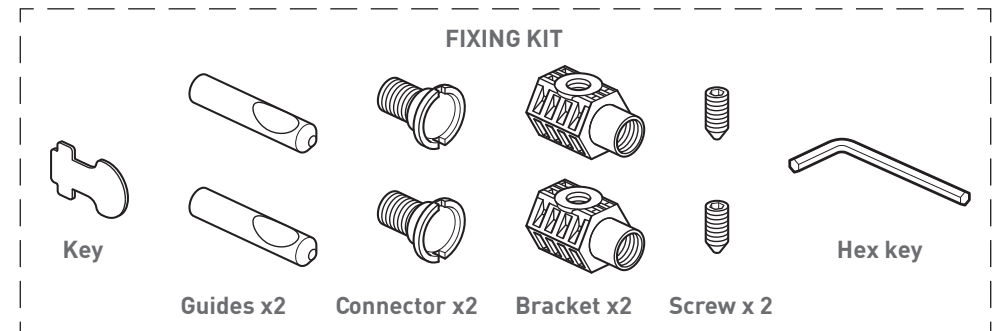

Installation

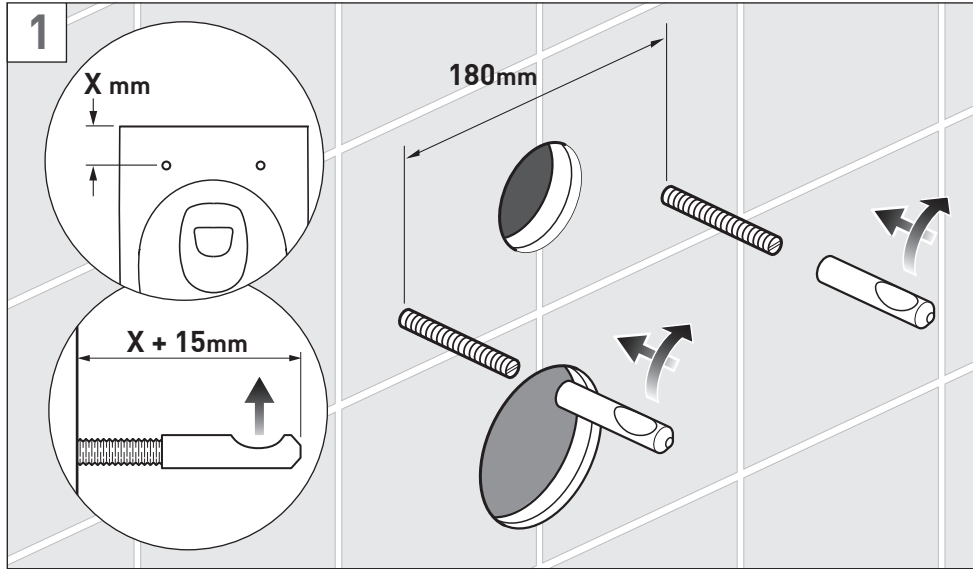

Measure from the back of the toilet to the centre of a fixing hole to find out **X**. Screw the guides onto the fixing bolts until they are fully engaged. The total length needs to equal **$X + 15$ mm** from the wall surface. Make sure that the cutout in the guide is facing upwards

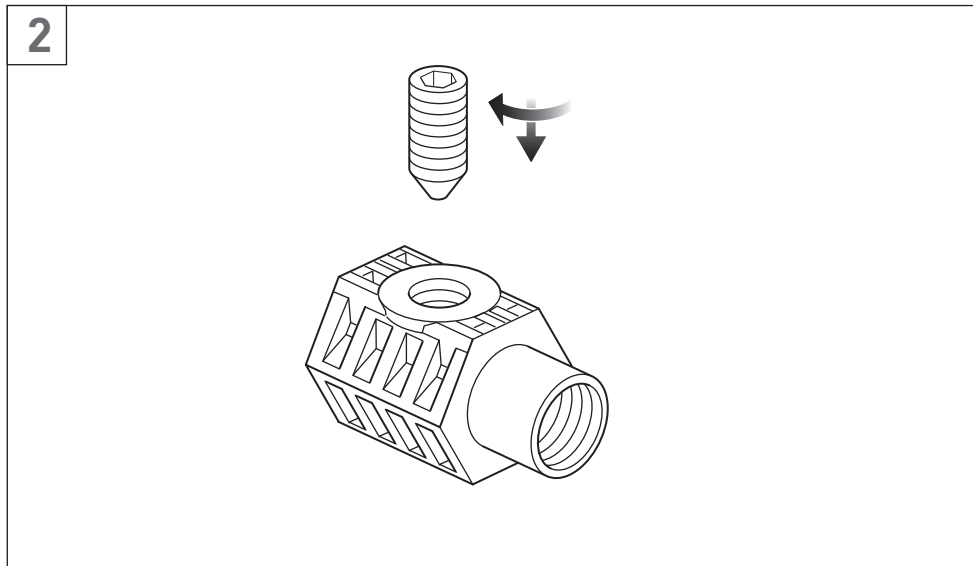

Screw a grub screw into each bracket but do not tighten.

Installation

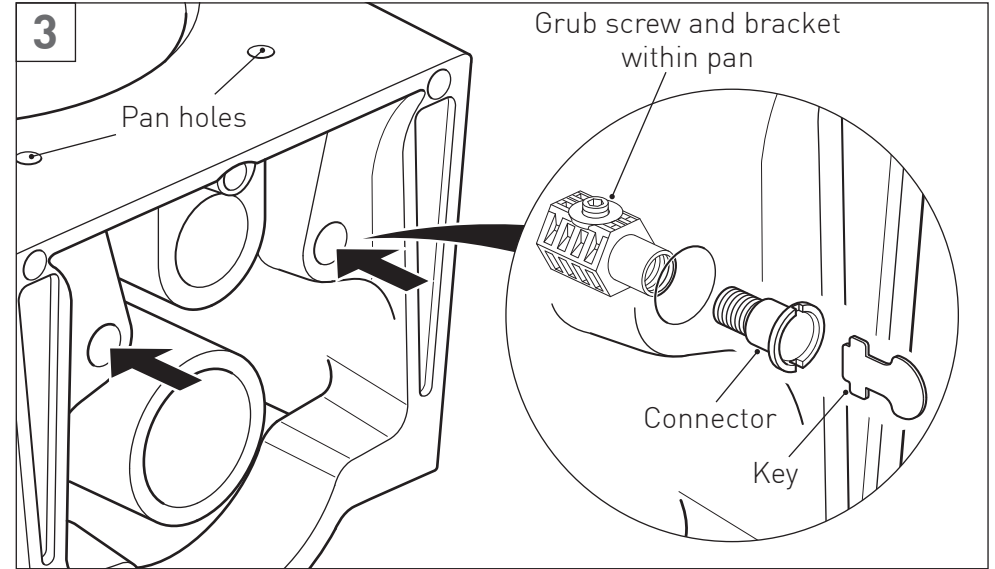

Hold the bracket inside the toilet and screw in the connector using the key, make sure the grub screw is facing upwards directly underneath the hole in the WC pan.

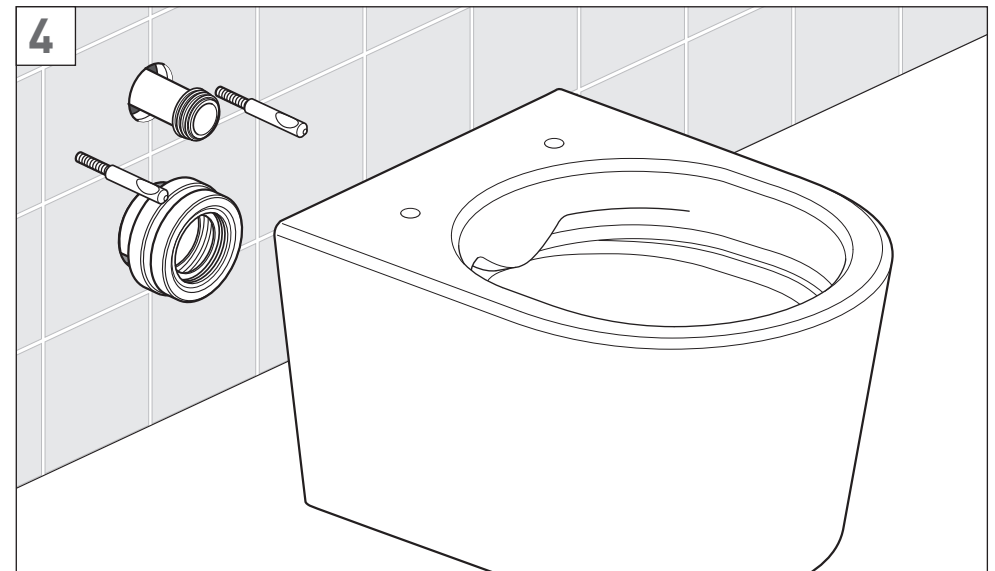

Slide the toilet over the guides and up to the wall.

Installation

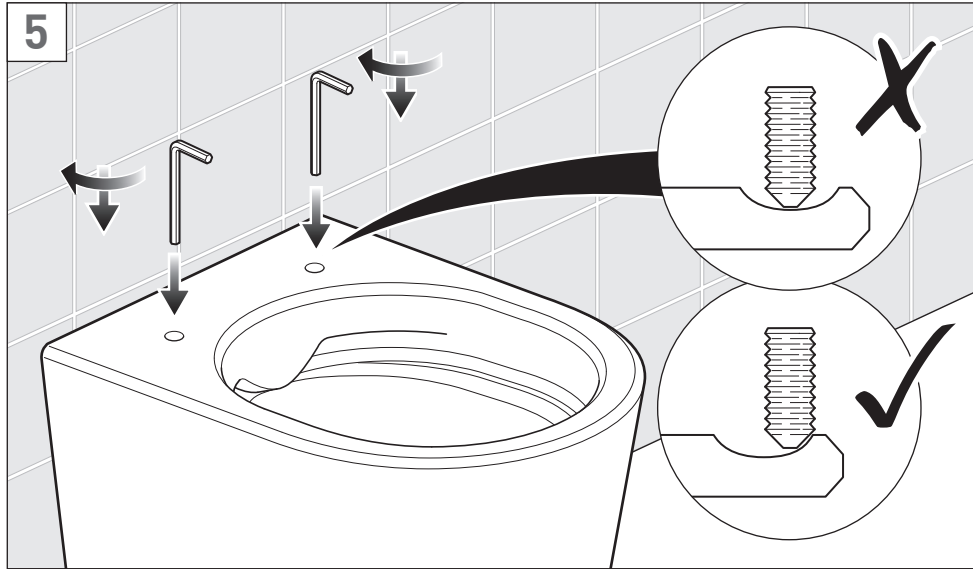

Fully tighten up the screws using the provided hex key. The screws need to hit the front of the slope in the guide so the toilet is pulled back towards the wall..

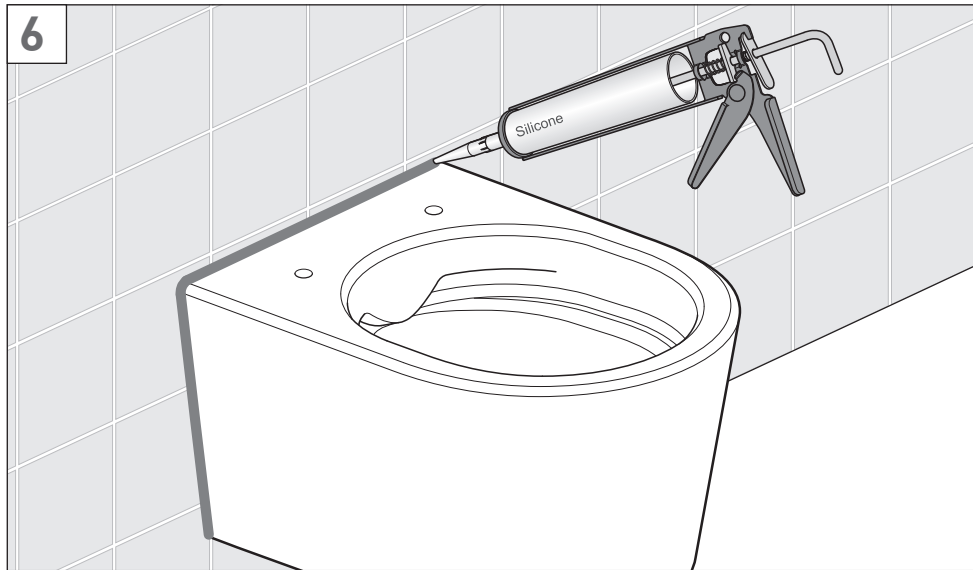

Apply a thin bead of silicone along the top and down the sides to seal against the tiled surface.

Guarantee

This VADO WC Pan comes with a 2 year guarantee as standard. Within this guarantee period, VADO will provide replacement parts only.

This standard guarantee may be extended by registering your product on our website at: <https://www.vado.com/support/guarantee>. Once registered this WC Pan will have a 25 year guarantee.

Guarantee Conditions

Our products are guaranteed against manufacturing defects from the date of purchase until the expiry of the relevant guarantee period shown above.

The guarantee is only valid if:

- The product has been installed, used and maintained in accordance with VADO's instructions and subjected to normal use only.
- The defect is not due to accident, misuse, neglect, or incorrect/inappropriate repair (other than by VADO or VADO authorised agents) or damage caused by foreign objects or substances.
- The extended guarantee is only available if you have completed the guarantee registration process.

This can be done via the VADO website or via telephone to our Aftersales team.

Registration must be completed within 6 months from the date of purchase. Under the extended guarantee period VADO will, at its option, offer to supply any replacement product (or component part) assessed to be defective **[SEE NOTE 1]**

- The guarantee (whether standard or extended) is non-transferable to any subsequent owner.
- Mould, Mildew build up, the effects of limescale and corrosion are not covered under this guarantee.
- This guarantee does not cover damage and/or malfunction caused by inappropriate cleaning (please refer to our recommended care guidelines).

All claims under the guarantee should be notified in the first instance to our Aftersales department, contact details below, this must be done no later than the last day of the relevant guarantee period.

All claims must be accompanied by proof of purchase (sales receipt or delivery note) from an official VADO dealer.

The guarantee does not extend to any consequential loss or damage.

After repair or replacement, the relevant guarantee period will be calculated from the original date of purchase.

VADO operates a policy of continuous product development and therefore reserves the right to change the product, packaging and documentation specifications without notice.

In situations where like-for-like replacements are not possible, VADO will endeavour to provide the closest alternative. E&OE.

NOTES:

[1] VADO reserves the right to charge in advance for a product (or replacement part) pending collection and investigation (at VADO expense) to confirm a defect is due to a manufacturing issue.

If a defect is found the charge will be refunded or cancelled.

This guarantee is in addition to and does not affect your statutory rights as a consumer.

Tel: 01934 745163 Email: aftersales@vado.com