

SPECIFICATION SHEET

COLLECTION: ZOO

PRODUCT CODE: ZOO-232NS-CP

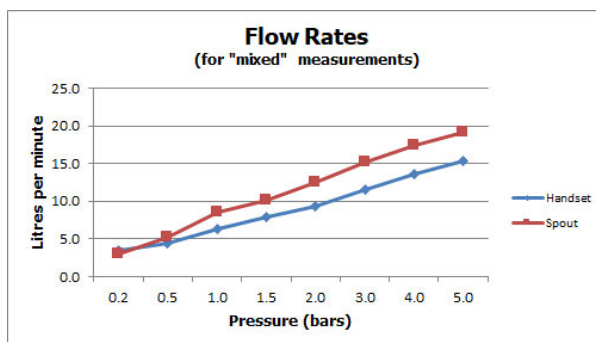

The flow rate displayed is calculated using ideal system conditions. This result should only be taken as an indication as the flow rate may vary depending on the specific in-situ configuration.

TAP TYPE

Bath Shower Mixer

WITH SHOWER KIT

Yes

WITH EASY-FIT BRACKETS

No

WITH INTEGRATED DIVERTER

No

WITH THERMOSTATIC TECHNOLOGY

No

FOR USE WITH BATH FILLER WASTE AND OVERFLOW

Yes

WITH BATH SPOUT

No

WITH AIR-INJECTION TECHNOLOGY

No

WITH WATER FLOW STRAIGHTENER

No

tel: 01934 744466
email: sales@vado.com
www.vado.com

WHERE INSPIRATION FLOWS
TAPS | SHOWERS | ACCESSORIES



SPECIFICATION SHEET

COLLECTION: ZOO

PRODUCT CODE: ZOO-232NS-CP

WITH WATER FLOW AERATOR

No

CONNECTIONS / FITTINGS

2 x 3/4" x 3/4" 600mm flexipipe connectors 1 x 2m shower hose 2 x 400 1/2" female flexipipe connectors to valve

SPARE PARTS

diverter cartridge F-803-33/2X ceramic cartridge CAR-KN40

DECK HOLE DRILL DIAMETER

Valve: 46mm Spout: 28mm Diverter: 44mm Handset: 32mm

STYLE

Round

HOLES

3 Hole

MOUNTING

Deck Mounted

PLUMBING SYSTEM SUITABILITY

Pumped System, Pressurised System

COLLECTION NAME

Zoo

FINISH

Chrome

RECOMMENDED FLOW REGULATOR

FR-FLEXI/8-PLA

MINIMUM OPERATING PRESSURE

3.0 Bar HP

tel: 01934 744466
email: sales@vado.com
www.vado.com

WHERE INSPIRATION FLOWS
TAPS | SHOWERS | ACCESSORIES



SPECIFICATION SHEET

COLLECTION: Z00
PRODUCT CODE: Z00-232NS-CP

MAXIMUM OPERATING PRESSURE

5.0 Bar HP

FLOW RATE AT 3.0 BAR FLOW PRESSURE

Spout: 15.2 l/min, Diverter: 11.6 l/min

GUARANTEE

15 Year Guarantee

tel: 01934 744466
email: sales@vado.com
www.vado.com

WHERE INSPIRATION FLOWS
TAPS | SHOWERS | ACCESSORIES



TECHNICAL DRAWING

COLLECTION: ZOO
PRODUCT CODE: ZOO-232NS-CP

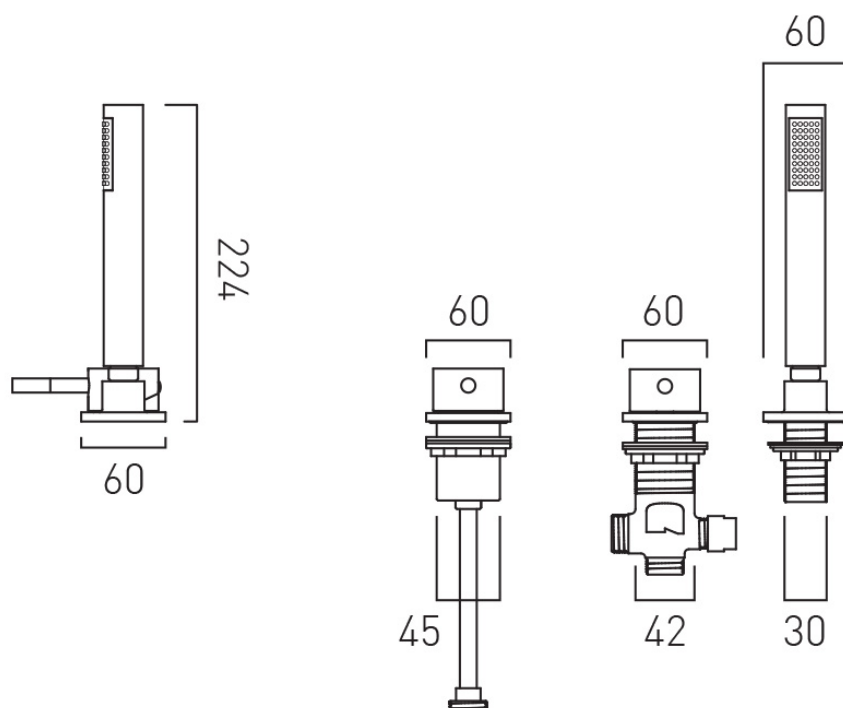

tel: 01934 744466
email: sales@vado.com
www.vado.com

WHERE INSPIRATION FLOWS
TAPS | SHOWERS | ACCESSORIES

