

SPECIFICATION SHEET

COLLECTION: I-TECH

PRODUCT CODE: AX-IR-100/AVA-CP



TAP TYPE

Infra-red

PLUMBING SYSTEM SUITABILITY

Pumped System, Combination Boiler, Pressurised System

MOUNTING

Deck Mounted

SPARE PARTS

Central Processing unit IR-100/CONTROL

WITH WATER FLOW AERATOR

No

NOTES

Rub clean aerator

Mains or battery operated

Takes standard AA batteries

Pair with the PRO-5001 for temperature control

COLLECTION NAME

I-Tech

FINISH

Chrome

RECOMMENDED FLOW REGULATOR

FR-100/5-PLA

tel: 01934 744466
email: sales@vado.com
www.vado.com

WHERE INSPIRATION FLOWS
TAPS | SHOWERS | FURNITURE



SPECIFICATION SHEET

COLLECTION: I-TECH

PRODUCT CODE: AX-IR-100/AVA-CP

MINIMUM OPERATING PRESSURE

1.0 Bar MP

MAXIMUM OPERATING PRESSURE

5.0 Bar HP

GUARANTEE

5 Year Guarantee

tel: 01934 744466
email: sales@vado.com
www.vado.com

WHERE INSPIRATION FLOWS
TAPS | SHOWERS | FURNITURE



TECHNICAL DRAWING

COLLECTION: I-TECH

PRODUCT CODE: AX-IR-100/AVA-CP

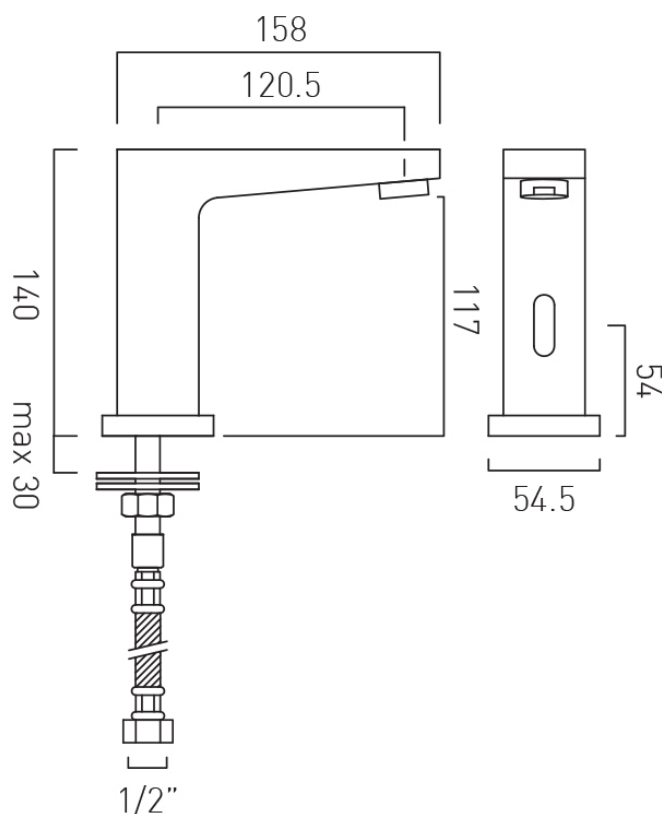

tel: 01934 744466
email: sales@vado.com
www.vado.com

WHERE INSPIRATION FLOWS
TAPS | SHOWERS | FURNITURE

