

# SPECIFICATION SHEET

COLLECTION: AXBRIDGE  
PRODUCT CODE: BC-AXB-109-BN

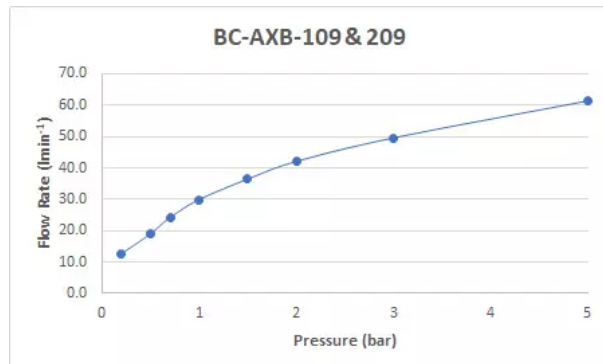

The flow rate displayed is calculated using ideal system conditions. This result should only be taken as an indication as the flow rate may vary depending on the specific in-situ configuration.

## TAP TYPE

Basin Mixer

## COLLECTION NAME

Axbridge

## FINISH

Bright Nickel

## RECOMMENDED FLOW REGULATOR

FR-106/6-PLA

## MINIMUM OPERATING PRESSURE

0.2 Bar LP

## MAXIMUM OPERATING PRESSURE

5.0 Bar HP

## GUARANTEE

15 Year Guarantee

## WITH ECOTURN COLD START TECHNOLOGY

No

## WITH WATER FLOW STRAIGHTENER

Yes

tel: 01934 744466  
email: [sales@vado.com](mailto:sales@vado.com)  
[www.vado.com](http://www.vado.com)

WHERE INSPIRATION FLOWS  
TAPS | SHOWERS | ACCESSORIES



# SPECIFICATION SHEET

COLLECTION: AXBRIDGE  
PRODUCT CODE: BC-AXB-109-BN

## WITH WATER FLOW AERATOR

No

## INSTALLATION TOLERANCES

min-max wall mount 56-81mm

## CONNECTIONS / FITTINGS

2 x 1/2" inlets

## SPARE PARTS

cold ceramic cartridge FL-501-RTC hot ceramic cartridge FL-501-LTC

## WASTE

with Pop-up Waste

## STYLE

Traditional, Cross Handles

## HOLES

3 Hole

## MOUNTING

Wall Mounted

## PLUMBING SYSTEM SUITABILITY

Gravity System, Pumped System, Combination Boiler, Pressurised System

# TECHNICAL DRAWING

COLLECTION: AXBRIDGE  
PRODUCT CODE: BC-AXB-109-BN

