

# SPECIFICATION SHEET

COLLECTION: AXBRIDGE

PRODUCT CODE: BC-AXB-149/RRK-BN

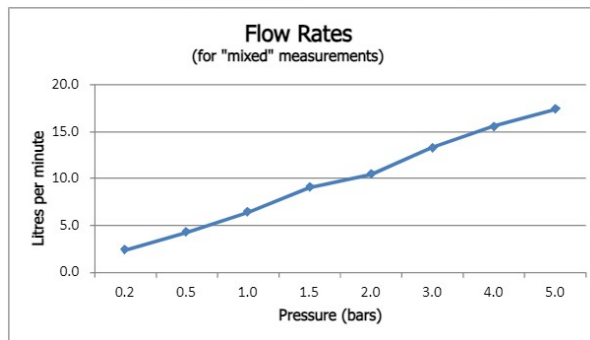

The flow rate displayed is calculated using ideal system conditions. This result should only be taken as an indication as the flow rate may vary depending on the specific in-situ configuration.

## SHOWER TYPE

Shower Column

## WITH SHOWER KIT

Yes

## WITH AIR-INJECTION TECHNOLOGY

No

## WITH EASY-FIT BRACKETS

No

## WITH CROSS-SPRAY TECHNOLOGY

No

## WITH INTEGRATED DIVERTER

Yes

## ADJUSTABLE FIXING FOR EASY RETRO FIT

No

## WITH THERMOSTATIC TECHNOLOGY

Yes

## SHOWER HEAD SIZE

200mm (8") shower head

tel: 01934 744466  
email: [sales@vado.com](mailto:sales@vado.com)  
[www.vado.com](http://www.vado.com)

WHERE INSPIRATION FLOWS  
TAPS | SHOWERS | ACCESSORIES



# SPECIFICATION SHEET

COLLECTION: AXBRIDGE  
PRODUCT CODE: BC-AXB-149/RRK-BN

## WITH WATER FLOW STRAIGHTENER

No

## SPARE PARTS

thermostatic cartridge V-702-34S ceramic cartridge FL-511-LTC

## STYLE

Traditional

## MOUNTING

Wall Mounted

## PLUMBING SYSTEM SUITABILITY

Pumped System, Combination Boiler, Pressurised System

## COLLECTION NAME

Axbridge

## FINISH

Bright Nickel

## MINIMUM OPERATING PRESSURE

1.0 Bar MP

## MAXIMUM OPERATING PRESSURE

5.0 Bar HP

## GUARANTEE

15 Year Guarantee

# TECHNICAL DRAWING

COLLECTION: AXBRIDGE

PRODUCT CODE: BC-AXB-149/RRK-BN

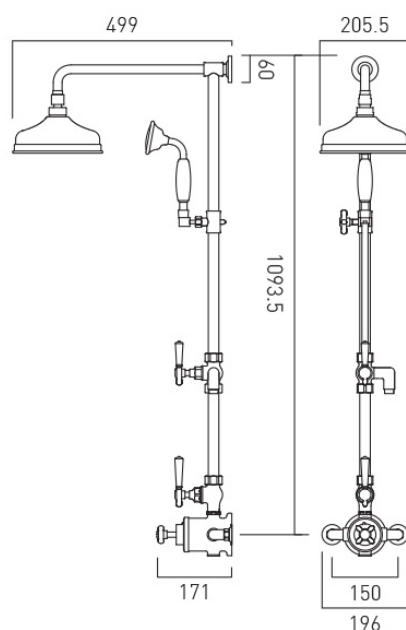

tel: 01934 744466  
email: sales@vado.com  
www.vado.com

WHERE INSPIRATION FLOWS  
TAPS | SHOWERS | ACCESSORIES

