

# SPECIFICATION SHEET

COLLECTION: ELEMENTS

PRODUCT CODE: ELW-100F/CC-C/P

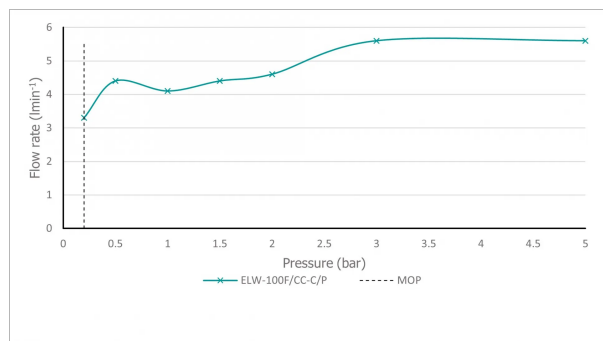

The flow rate displayed is calculated using ideal system conditions. This result should only be taken as an indication as the flow rate may vary depending on the specific in-situ configuration.

## TAP TYPE

Basin Mixer

## COLLECTION NAME

Elements

## FINISH

Chrome

## RECOMMENDED FLOW REGULATOR

5 l/m flow regulator fitted as standard

## MINIMUM OPERATING PRESSURE

0.2 Bar LP

## MAXIMUM OPERATING PRESSURE

5.0 Bar HP

## GUARANTEE

15 Year Guarantee

## WITH ECOTURN COLD START TECHNOLOGY

No

## WITH WATER FLOW STRAIGHTENER

No

tel: 01934 744466  
email: sales@vado.com  
www.vado.com

WHERE INSPIRATION FLOWS  
TAPS | SHOWERS | ACCESSORIES



# SPECIFICATION SHEET

COLLECTION: ELEMENTS

PRODUCT CODE: ELW-100F/CC-C/P

## WITH SWIVEL SPOUT

With swivel spout

## WITH WATER FLOW AERATOR

Yes

## CONNECTIONS / FITTINGS

2 x 1/2" 400mm flexipipe connections

## SPARE PARTS

cold ceramic cartridge C-206-RTC hot ceramic cartridge C-206-LTC

## DECK HOLE DRILL DIAMETER

35mm

## WASTE

with Universal Basin Waste

## MOUNTING

Deck Mounted

## PLUMBING SYSTEM SUITABILITY

Gravity System, Pumped System, Combination Boiler, Pressurised System

# TECHNICAL DRAWING

COLLECTION: ELEMENTS

PRODUCT CODE: ELW-100F/CC-C/P

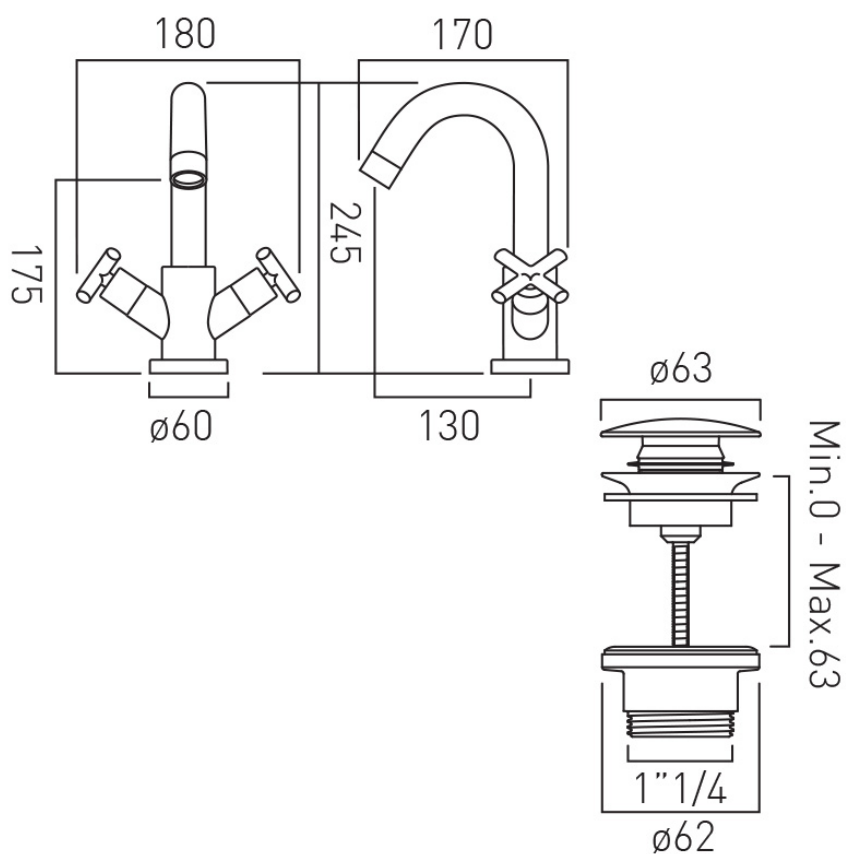

tel: 01934 744466  
email: sales@vado.com  
www.vado.com

WHERE INSPIRATION FLOWS  
TAPS | SHOWERS | ACCESSORIES

