

SPECIFICATION SHEET

COLLECTION:
PRODUCT CODE: WG-095S-F/C



GUARANTEE

6 Year Guarantee

CISTERN TYPE

Concealed Short Frame Cistern

FLUSH PLATE DEPTH TOLERANCE

70mm

DUAL FLUSH

Yes 6L/3L adjustable to 4L/2.6L

INLET

Side Mounted 1/2"

TOILET SUITABILITY

Wall Hung

HEIGHT ADJUSTMENT

250mm

WEIGHT SUPPORT

400kg

SOIL PIPE HEIGHT ADJUSTMENT

30mm

tel: 01934 744466
email: sales@vado.com
www.vado.com

WHERE INSPIRATION FLOWS
TAPS | SHOWERS | FURNITURE



SPECIFICATION SHEET

COLLECTION:
PRODUCT CODE: WG-095S-F/C

FIXING BRACKETS

Block Wall , Stud Frame

WITH INTEGRAL INTERNAL 1/4 TURN LEVER ISOLATION VALVE

Yes

WITH INTEGRAL INTERNAL DEBRIS FILTER

Yes

WITH FINISHED HEIGHT FIXING LOCATION MARKING

Yes



TECHNICAL DRAWING

COLLECTION:
PRODUCT CODE: WG-095S-F/C

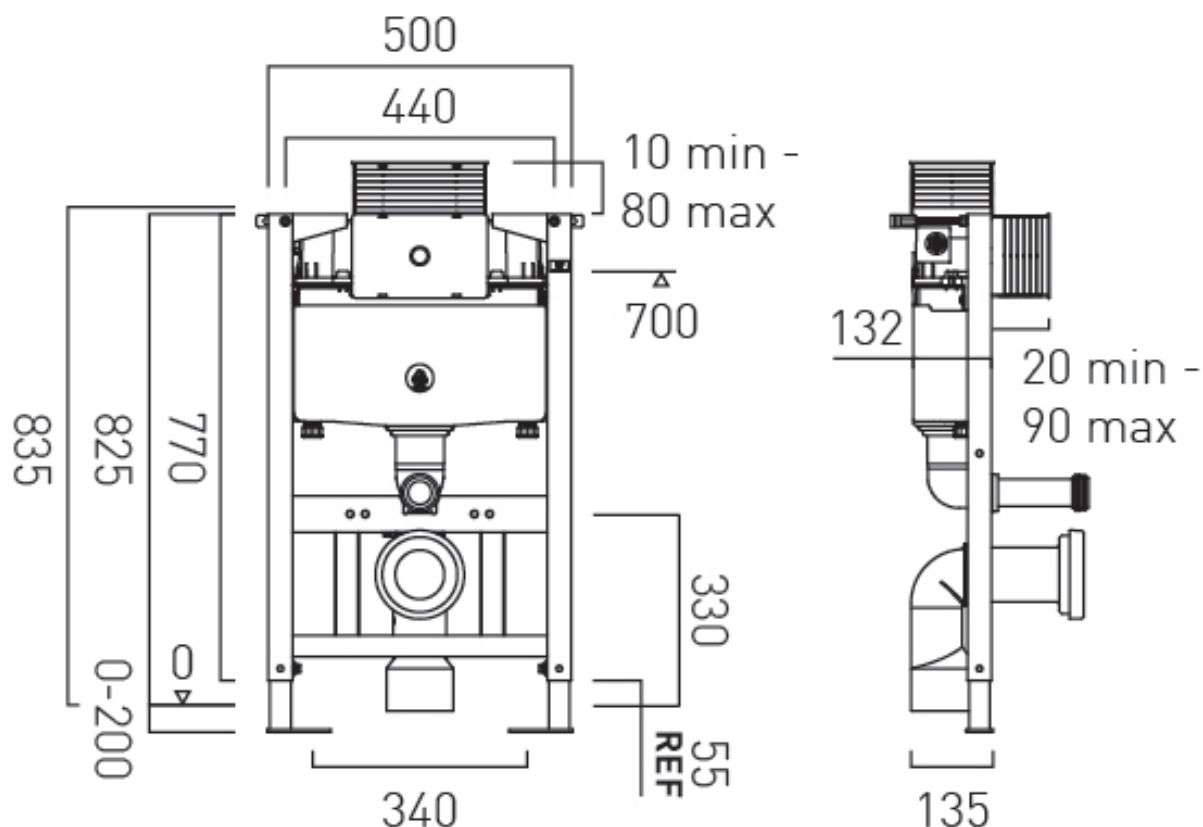

tel: 01934 744466
email: sales@vado.com
www.vado.com

WHERE INSPIRATION FLOWS
TAPS | SHOWERS | FURNITURE

