

# SPECIFICATION SHEET

COLLECTION: ELEMENTS  
PRODUCT CODE: ELW-101F-C/P

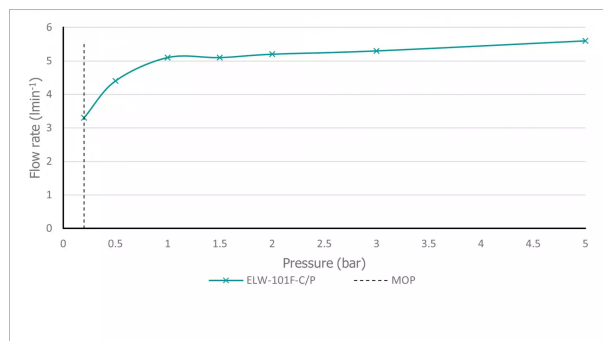

The flow rate displayed is calculated using ideal system conditions. This result should only be taken as an indication as the flow rate may vary depending on the specific in-situ configuration.

## TAP TYPE

Basin Mixer

## FINISH

Chrome

## COLLECTION NAME

Elements

## GUARANTEE

15 Year Guarantee

## PLUMBING SYSTEM SUITABILITY

Gravity System, Pumped System, Combination Boiler, Pressurised System

## MINIMUM OPERATING PRESSURE

0.2 Bar LP

## MAXIMUM OPERATING PRESSURE

5.0 Bar HP

## HOLES

3 Hole

## MOUNTING

Deck Mounted

tel: 01934 744466  
email: sales@vado.com  
www.vado.com

WHERE INSPIRATION FLOWS  
TAPS | SHOWERS | FURNITURE



# SPECIFICATION SHEET

COLLECTION: ELEMENTS  
PRODUCT CODE: ELW-101F-C/P

## WASTE

With Pop-up Waste

## RECOMMENDED FLOW REGULATOR

5 l/m flow regulator fitted as standard

## WITH ECOTURN COLD START TECHNOLOGY

No

## WITH WATER FLOW STRAIGHTENER

No

## WITH WATER FLOW AERATOR

Yes

## CONNECTIONS / FITTINGS

2 x 1/2" 600mm flexipipe connections

## DECK HOLE DRILL DIAMETER

Valve: 27mm Spout: 30mm

## SPARE PARTS

cold ceramic cartridge C-206-RTC hot ceramic cartridge C-206-LTC

# TECHNICAL DRAWING

COLLECTION: ELEMENTS  
PRODUCT CODE: ELW-101F-C/P

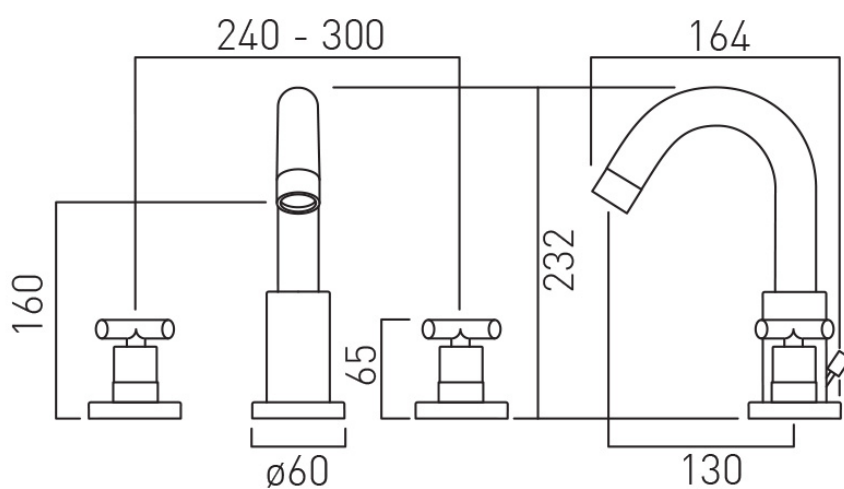

tel: 01934 744466  
email: sales@vado.com  
www.vado.com

WHERE INSPIRATION FLOWS  
TAPS | SHOWERS | FURNITURE

