

SPECIFICATION SHEET

COLLECTION: LIFE

PRODUCT CODE: LIF-109S/A-200-C/P

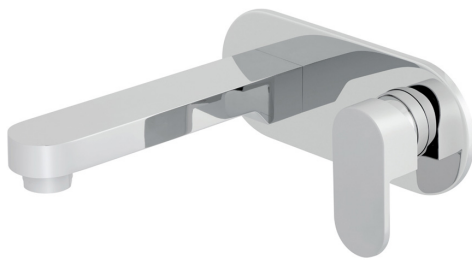

TAP TYPE

Basin Mixer

COLLECTION NAME

Life

FINISH

Chrome

RECOMMENDED FLOW REGULATOR

FR-106/5-PLA

MINIMUM OPERATING PRESSURE

0.2 Bar LP

MAXIMUM OPERATING PRESSURE

5.0 Bar HP

GUARANTEE

15 Year Guarantee

HANDLES

Single Lever

WITH ECOTURN COLD START TECHNOLOGY

No

tel: 01934 744466
email: sales@vado.com
www.vado.com

WHERE INSPIRATION FLOWS
TAPS | SHOWERS | ACCESSORIES



SPECIFICATION SHEET

COLLECTION: LIFE

PRODUCT CODE: LIF-109S/A-200-C/P

WITH WATER FLOW STRAIGHTENER

No

WITH WATER FLOW AERATOR

Yes

INSTALLATION TOLERANCES

min-max wall mount 53-70mm

CONNECTIONS / FITTINGS

2 x 1/2" inlets

SPARE PARTS

ceramic cartridge CAR-K35B

STYLE

Oval

HOLES

2 Hole

MOUNTING

Wall Mounted

PLUMBING SYSTEM SUITABILITY

Gravity System, Pumped System, Combination Boiler, Pressurised System



TECHNICAL DRAWING

COLLECTION: LIFE

PRODUCT CODE: LIF-109S/A-200-C/P

