

# SPECIFICATION SHEET

COLLECTION: CAMEO  
PRODUCT CODE: CAM-131T-MW

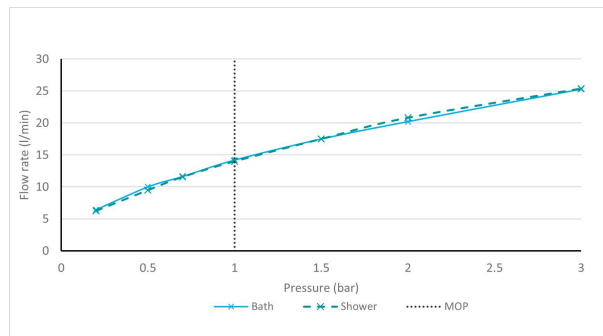
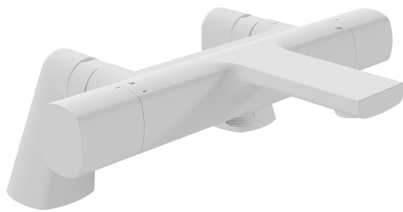

The flow rate displayed is calculated using ideal system conditions. This result should only be taken as an indication as the flow rate may vary depending on the specific in-situ configuration.

## TAP TYPE

Bath Shower Mixer

## PLUMBING SYSTEM SUITABILITY

Combination Boiler

## HANDLES

2 Handle

## HOLES

2 Hole

## MOUNTING

Deck Mounted

## WITH INTEGRATED DIVERTER

No

## WITH EASY-FIT BRACKETS

No

## WITH SHOWER KIT

No

## WITH THERMOSTATIC TECHNOLOGY

Yes

tel: 01934 744466  
email: sales@vado.com  
www.vado.com

WHERE INSPIRATION FLOWS  
TAPS | SHOWERS | FURNITURE



# SPECIFICATION SHEET

COLLECTION: CAMEO  
PRODUCT CODE: CAM-131T-MW

## FOR USE WITH BATH FILLER WASTE AND OVERFLOW

No

## MINIMUM OPERATING PRESSURE

1.0 Bar MP

## MAXIMUM OPERATING PRESSURE

5.0 Bar HP

## WITH BATH SPOUT

Yes

## WITH AIR-INJECTION TECHNOLOGY

No

## WITH WATER FLOW STRAIGHTENER

Yes

## WITH WATER FLOW AERATOR

No

## CONNECTIONS / FITTINGS

2x 3/4" 50mm threaded connection on legs

## DECK HOLE DRILL DIAMETER

28-25mm

## SPARE PARTS

Thermostatic cartridge V-704-34S Diverter cartridge C-801-33/2P

## STYLE

Square

## FINISH

Matt White



# SPECIFICATION SHEET

COLLECTION: CAMEO  
PRODUCT CODE: CAM-131T-MW

## COLLECTION NAME

Cameo

## GUARANTEE

10 Year Guarantee

tel: 01934 744466  
email: [sales@vado.com](mailto:sales@vado.com)  
[www.vado.com](http://www.vado.com)

WHERE INSPIRATION FLOWS  
TAPS | SHOWERS | FURNITURE



# TECHNICAL DRAWING

COLLECTION: CAMEO  
PRODUCT CODE: CAM-131T-MW

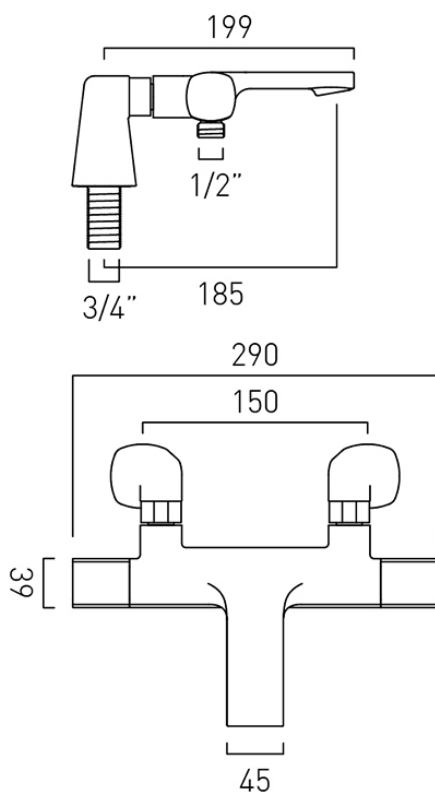

tel: 01934 744466  
email: sales@vado.com  
www.vado.com

WHERE INSPIRATION FLOWS  
TAPS | SHOWERS | FURNITURE

