

SPECIFICATION SHEET

COLLECTION: PHASE
PRODUCT CODE: PHA-130+K-C/P

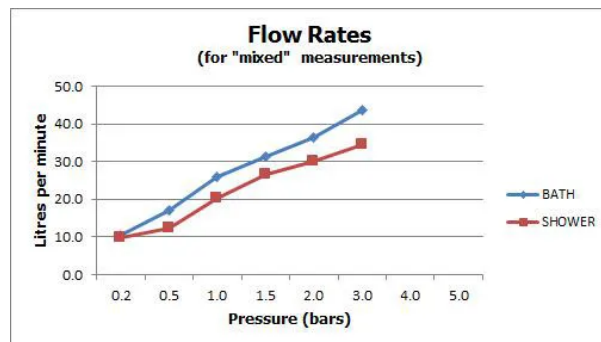

The flow rate displayed is calculated using ideal system conditions. This result should only be taken as an indication as the flow rate may vary depending on the specific in-situ configuration.

TAP TYPE

Bath Shower Mixer

FOR USE WITH BATH FILLER WASTE AND OVERFLOW

No

WITH SHOWER KIT

Yes

WITH BATH SPOUT

No

WITH EASY-FIT BRACKETS

No

WITH AIR-INJECTION TECHNOLOGY

No

WITH INTEGRATED DIVERTER

No

WITH WATER FLOW STRAIGHTENER

Yes

WITH THERMOSTATIC TECHNOLOGY

No

tel: 01934 744466
email: sales@vado.com
www.vado.com

WHERE INSPIRATION FLOWS
TAPS | SHOWERS | ACCESSORIES



SPECIFICATION SHEET

COLLECTION: PHASE
PRODUCT CODE: PHA-130+K-C/P

WITH WATER FLOW AERATOR

No

CONNECTIONS / FITTINGS

2 x 3/4" 52.5mm male threaded connections

SPARE PARTS

cold ceramic cartridge C-302-RTC hot ceramic cartridge C-302-LTC

DECK HOLE DRILL DIAMETER

2 x 28-30mm

HOLES

2 Hole

MOUNTING

Deck Mounted

PLUMBING SYSTEM SUITABILITY

Gravity System, Pumped System, Combination Boiler, Pressurised System

COLLECTION NAME

Phase

FINISH

Chrome

RECOMMENDED FLOW REGULATOR

FR-SHOWER/9-C/P

MINIMUM OPERATING PRESSURE

0.2 Bar LP

MAXIMUM OPERATING PRESSURE

5.0 Bar HP

SPECIFICATION SHEET

COLLECTION: PHASE
PRODUCT CODE: PHA-130+K-C/P

GUARANTEE
15 Year Guarantee

tel: 01934 744466
email: sales@vado.com
www.vado.com

WHERE INSPIRATION FLOWS
TAPS | SHOWERS | ACCESSORIES



TECHNICAL DRAWING

COLLECTION: PHASE
PRODUCT CODE: PHA-130+K-C/P

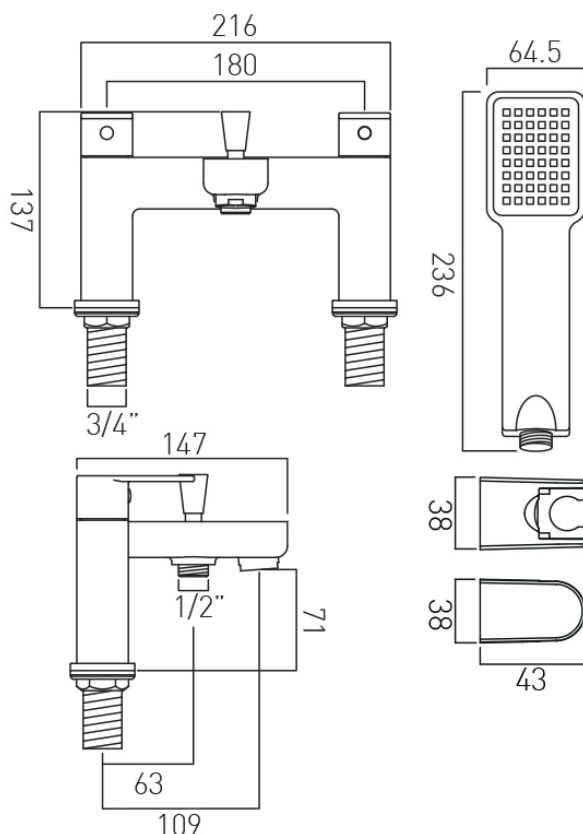

tel: 01934 744466
email: sales@vado.com
www.vado.com

WHERE INSPIRATION FLOWS
TAPS | SHOWERS | ACCESSORIES

