

SPECIFICATION SHEET

COLLECTION: VELO

PRODUCT CODE: VEL-149RRK-SQ-CP

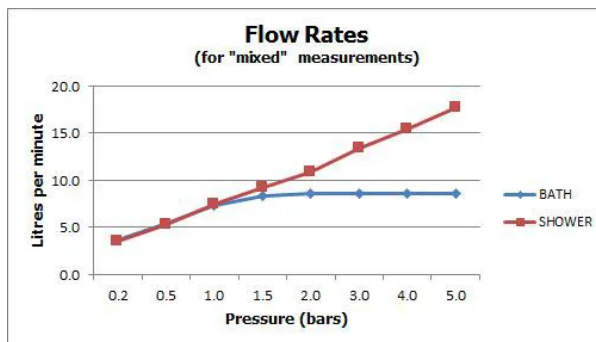

The flow rate displayed is calculated using ideal system conditions. This result should only be taken as an indication as the flow rate may vary depending on the specific in-situ configuration.

SHOWER TYPE

Shower Column

WITH AIR-INJECTION TECHNOLOGY

No

WITH CROSS-SPRAY TECHNOLOGY

No

ADJUSTABLE FIXING FOR EASY RETRO FIT

No

WITH SHOWER KIT

No

VALVE TYPE

Exposed

WITH EASY-FIT BRACKETS

No

WITH INTEGRATED DIVERTER

No

WITH THERMOSTATIC TECHNOLOGY

No

tel: 01934 744466
email: sales@vado.com
www.vado.com

WHERE INSPIRATION FLOWS
TAPS | SHOWERS | FURNITURE



SPECIFICATION SHEET

COLLECTION: VELO

PRODUCT CODE: VEL-149RRK-SQ-CP

SHOWER PACKAGE DESCRIPTION

- square thermostatic shower valve with integrated diverter
- rigid riser with single function shower head and shower handset
- 200mm square shower head
- 200mm height adjustment tolerance:
min 940mm – max 1140mm
- 18mm depth adjustment tolerance:
min 54mm – max 72mm
- offset connectors and easy-fit brackets included

WITH WATER FLOW STRAIGHTENER

No

SPARE PARTS

thermostatic cartridge V-703-34S flow cartridge VEL-002A-C/P

PLUMBING SYSTEM SUITABILITY

Pumped System, Combination Boiler, Pressurised System

COLLECTION NAME

Velo

FINISH

Chrome

MINIMUM OPERATING PRESSURE

1.0 Bar MP

MAXIMUM OPERATING PRESSURE

5.0 Bar HP

GUARANTEE

15 Year Guarantee

TECHNICAL DRAWING

COLLECTION: VELO

PRODUCT CODE: VEL-149RRK-SQ-CP

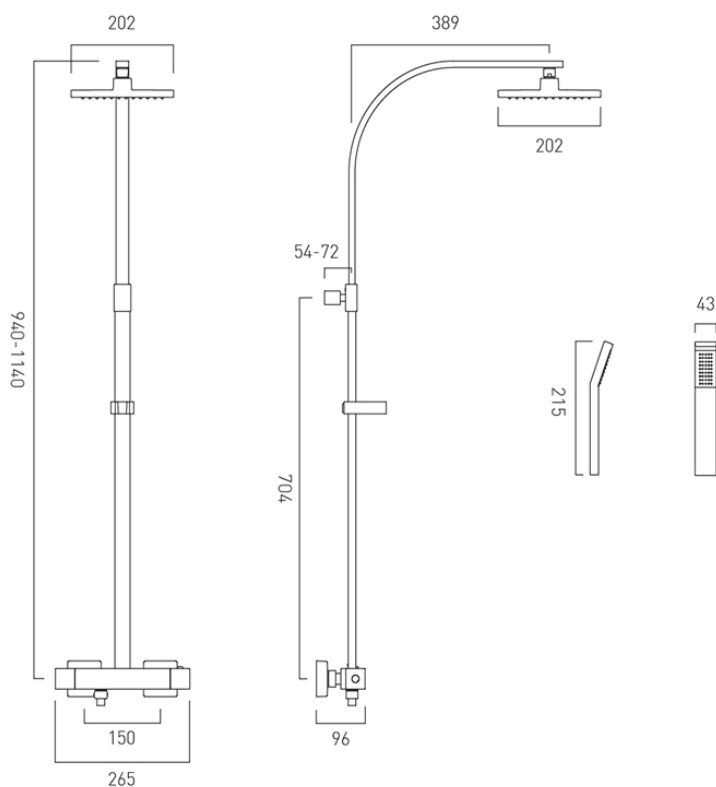

tel: 01934 744466
email: sales@vado.com
www.vado.com

WHERE INSPIRATION FLOWS
TAPS | SHOWERS | FURNITURE

