

SPECIFICATION SHEET

COLLECTION: AQUABLADE

PRODUCT CODE: AQB-149RRK-SQ-CP



SHOWER TYPE

Shower Column

VALVE TYPE

Exposed

WITH AIR-INJECTION TECHNOLOGY

No

WITH EASY-FIT BRACKETS

No

WITH CROSS-SPRAY TECHNOLOGY

No

WITH INTEGRATED DIVERTER

No

ADJUSTABLE FIXING FOR EASY RETRO FIT

No

WITH THERMOSTATIC TECHNOLOGY

No

WITH SHOWER KIT

No

tel: 01934 744466
email: sales@vado.com
www.vado.com

WHERE INSPIRATION FLOWS
TAPS | SHOWERS | FURNITURE



SPECIFICATION SHEET

COLLECTION: AQUABLADE
PRODUCT CODE: AQB-149RRK-SQ-CP

SHOWER PACKAGE DESCRIPTION

- square thermostatic shower valve with integrated diverter and rigid riser
- Aquablade 300mm x 200mm rectangular shower head
- Aquablade square single function shower handset
- 200mm height adjustment tolerance:
min 940mm – max 1140mm
- 18mm depth adjustment tolerance:
min 54mm – max 72mm
- offset connectors and easy-fit brackets included

WITH WATER FLOW STRAIGHTENER

No

SPARE PARTS

thermostatic cartridge V-703-34S flow cartridge VEL-002A-C/P

PLUMBING SYSTEM SUITABILITY

Pumped System, Combination Boiler, Pressurised System

COLLECTION NAME

Aquablade

FINISH

Chrome

MINIMUM OPERATING PRESSURE

1.0 Bar MP

MAXIMUM OPERATING PRESSURE

5.0 Bar HP

GUARANTEE

15 Year Guarantee

tel: 01934 744466
email: sales@vado.com
www.vado.com

WHERE INSPIRATION FLOWS
TAPS | SHOWERS | FURNITURE



TECHNICAL DRAWING

COLLECTION: AQUABLADE

PRODUCT CODE: AQB-149RRK-SQ-CP

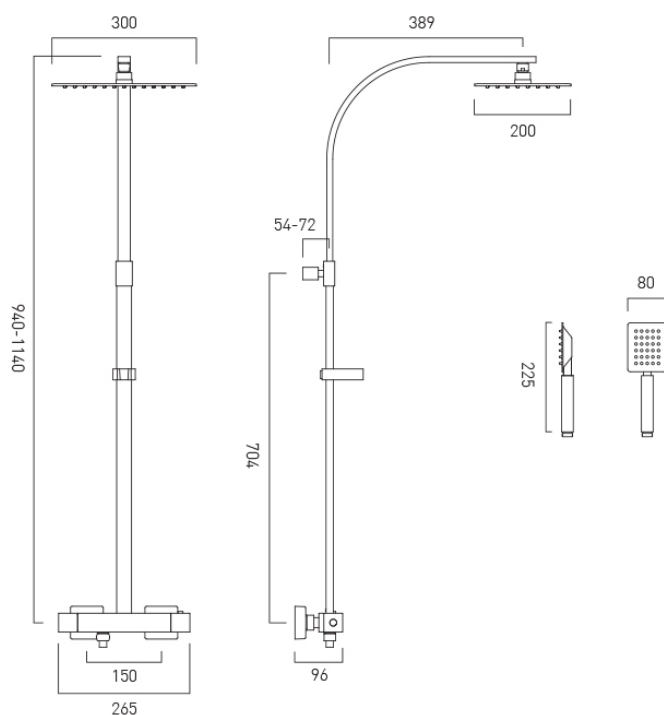

tel: 01934 744466
email: sales@vado.com
www.vado.com

WHERE INSPIRATION FLOWS
TAPS | SHOWERS | FURNITURE

