

SPECIFICATION SHEET

COLLECTION: SHOWERING SOLUTIONS
PRODUCT CODE: IND-SFSRK/RO-ATM-BRN

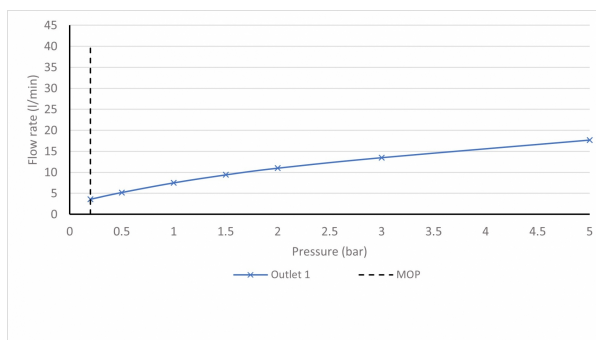

The flow rate displayed is calculated using ideal system conditions. This result should only be taken as an indication as the flow rate may vary depending on the specific in-situ configuration.

SHOWER TYPE

Slide Rail Shower Kit

SELF-CLEANING

No

SLIDE RAIL LENGTH

805mm slide rail with twist control 900mm overall rail length

WITH CROSS-SPRAY TECHNOLOGY

No

ADJUSTABLE FIXING FOR EASY RETRO FIT

No

WITH TWIST CONTROL

No

WITH PUSH BUTTON CONTROL

No

WITH HOSE RETAINER

No

RUB-CLEAN NOZZLES

Yes

tel: 01934 744466
email: sales@vado.com
www.vado.com

WHERE INSPIRATION FLOWS
TAPS | SHOWERS | FURNITURE



SPECIFICATION SHEET

COLLECTION: SHOWERING SOLUTIONS
PRODUCT CODE: IND-SFSRK/RO-ATM-BRN

FUNCTIONS

1

WITH AIR-INJECTION TECHNOLOGY

Yes

HOSE

with 150cm smooth hose

MOUNTING

Wall Mounted

PLUMBING SYSTEM SUITABILITY

Gravity System, Pumped System, Combination Boiler, Pressurised System

COLLECTION NAME

Showering Solutions

FINISH

Brushed Nickel

MINIMUM OPERATING PRESSURE

0.2 Bar LP

MAXIMUM OPERATING PRESSURE

5.0 Bar HP

GUARANTEE

15 Year Guarantee



TECHNICAL DRAWING

COLLECTION: SHOWERING SOLUTIONS
PRODUCT CODE: IND-SFSRK/RO-ATM-BRN

