

SPECIFICATION SHEET

COLLECTION: VICTORIANA

PRODUCT CODE: AX-VIC-131/S/CD-CP



TAP TYPE

Bath Shower Mixer

FOR USE WITH BATH FILLER WASTE AND OVERFLOW

No

WITH SHOWER KIT

Yes

WITH BATH SPOUT

No

WITH EASY-FIT BRACKETS

No

WITH AIR-INJECTION TECHNOLOGY

No

WITH INTEGRATED DIVERTER

No

WITH WATER FLOW STRAIGHTENER

No

WITH THERMOSTATIC TECHNOLOGY

No

tel: 01934 744466
email: sales@vado.com
www.vado.com

WHERE INSPIRATION FLOWS
TAPS | SHOWERS | ACCESSORIES



SPECIFICATION SHEET

COLLECTION: VICTORIANA
PRODUCT CODE: AX-VIC-131/S/CD-CP

WITH WATER FLOW AERATOR

No

CONNECTIONS / FITTINGS

2 x 3/4" x 50mm male threaded connections

HANDLES

2 Handle

SPARE PARTS

Cold Ceramic cartridge C-201-RTC Hot Ceramic cartridge C-201-LTC

DECK HOLE DRILL DIAMETER

27mm

HOLES

2 Hole

MOUNTING

Deck Mounted

PLUMBING SYSTEM SUITABILITY

Gravity System, Pumped System, Combination Boiler, Pressurised System

COLLECTION NAME

Victoriana

FINISH

Chrome

RECOMMENDED FLOW REGULATOR

FR-SHOWER/9-C/P

MINIMUM OPERATING PRESSURE

0.2 Bar LP

SPECIFICATION SHEET

COLLECTION: VICTORIANA

PRODUCT CODE: AX-VIC-131/S/CD-CP

MAXIMUM OPERATING PRESSURE

5.0 Bar HP

GUARANTEE

10 Year Guarantee

tel: 01934 744466
email: sales@vado.com
www.vado.com

WHERE INSPIRATION FLOWS
TAPS | SHOWERS | ACCESSORIES



TECHNICAL DRAWING

COLLECTION: VICTORIANA

PRODUCT CODE: AX-VIC-131/S/CD-CP

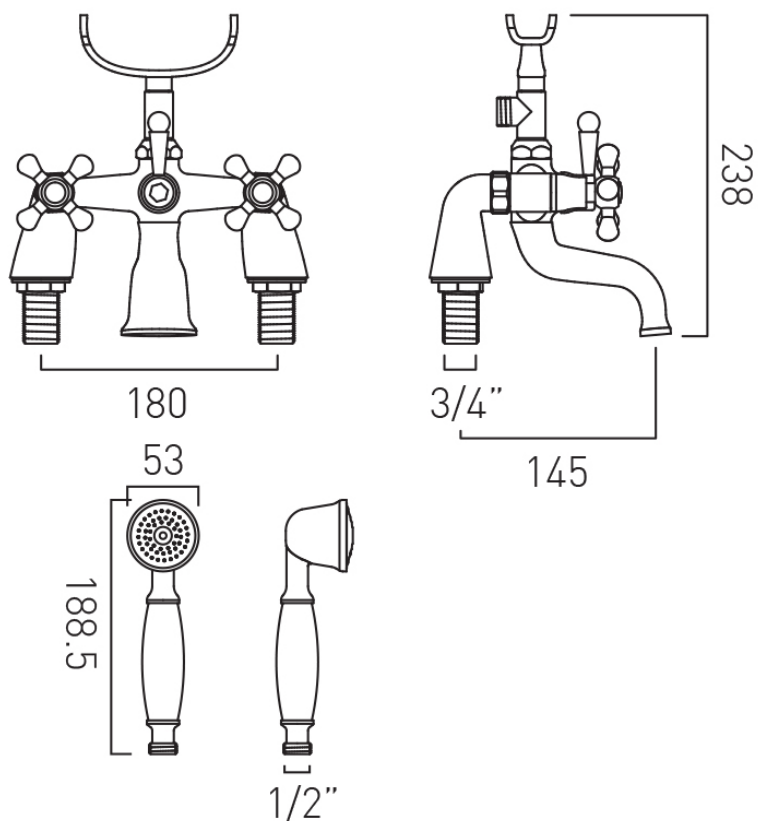

tel: 01934 744466
email: sales@vado.com
www.vado.com

WHERE INSPIRATION FLOWS
TAPS | SHOWERS | ACCESSORIES

